

SKALS

- we'll sort it out!

Brushing machine

Type: BM608, BM908, BM1208, BM616, BM916, BM1216, BM1526

Gentle brushing for both wet and dry products



Functions

- Dirt and soil removal by brushes
- The skins are lightened – inspection is made easier
- Both manual and automatically inspection is optimized
- The products visually appears as better quality
- Last roller is mounted w. rubber discs for gentle outflow

Options

- Vacuum cleaner for dust removal
- Integrated bypass conveyor - brushing optional
- Stainless steel version

Variants

- BM608, BM908, BM1208 – 8 brushes
- BM616, BM916, BM1216 – 16 brushes
- BM1526 – 26 brushes



Skals Maskinfabrik A/S
Hovedgaden 56 • DK-8832 Skals
tlf. +45 86 69 43 11 • fax. +45 86694999
CVR / VAT 17 21 80 18
skals.dk • www.skals.dk



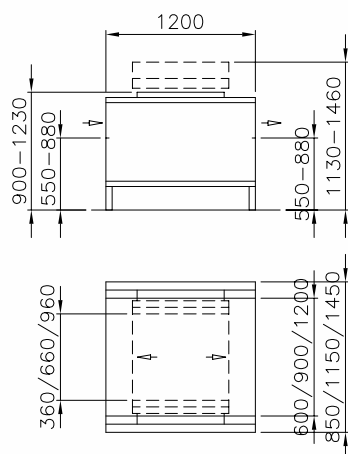

BM608/908/1208 + TPG5R

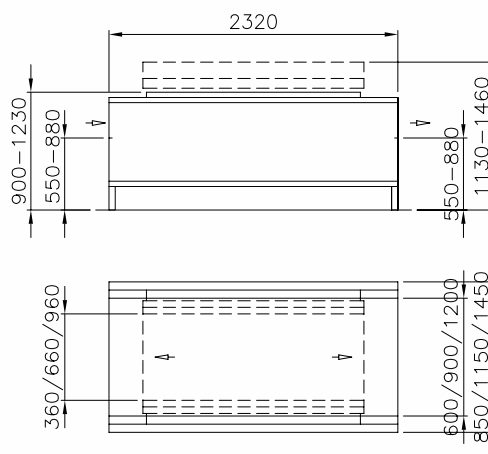

BM616/916/1216 + TPG5R

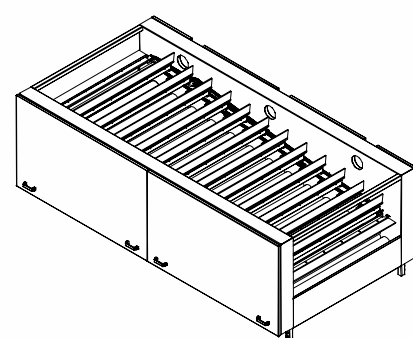
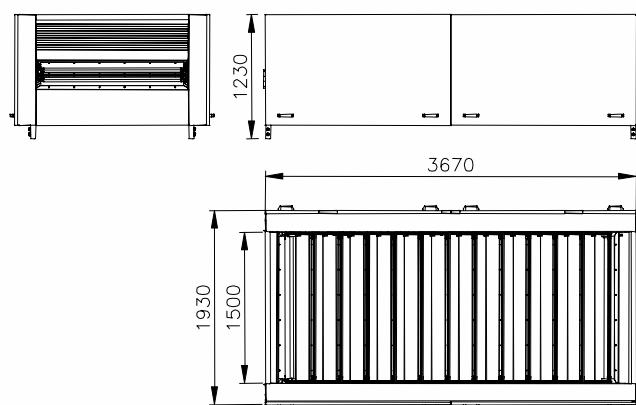
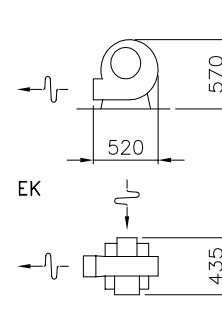

BM1526

Type:	BM608	BM908	BM1208	BM616	BM916	BM1216	BM1526
Kapacitet, Capacity, Leistung	5 t/h	8 t/h	11 t/h	12 t/h	18 t/h	24 t/h	30 t/h
Arbejdsbr. Working width, Arbeitsbreite	600 mm	900 mm	1200 mm	600 mm	900 mm	1200 mm	1500 mm
Børstevalser, Rollerbrushes, Bürstenwalzen	7	7	7	15	15	15	23
Gummivalser, Rubber rollers, Gummiwalzen	1	1	1	1	1	1	3
Motor.	0,37 kW.	0,55 kW.	0,75 kW.	1,1 kW.	1,1 kW.	2,2 kW.	26*0,25 kW
Vægt, Weight, Gewicht	165 kg	200 kg	235 kg	340 kg	410 kg	480 kg	825 kg

	производит-ть	ширина щеток	кол-во роликов	мотор
BM 608	до 5 тн/час	570	8	0,37 кВт
BM 908	До 8 тн/час	870	8	0,55 кВт
BM 1208	до 11 тн/час	1170	8	0,75 кВт
BM 616	до 12 тн/час	570	16	1,1 кВт
BM 916	до 18 тн/час	870	16	1,1 кВт
BM 1216	до 24 тн/час	1170	16	2.2 кВт
BM 1526	до 30 тн/час	1470	26	26*0.25 кВт