

SKALS

- we'll sort it out!

Rullerenser

Type: R 608 / R 908 / R 1210 / R 1510

Skånsom men effektiv rensning af kartofler



Funktioner

- Roterende rensvalser m. gummiskiver
- Jord, sand, spirer osv. rulles effektivt af produkterne
- Fjedrefingre mellem gummiskiver renholder valserne
- Jord og skidt ledes nedenud

Optioner

- Integreret pigbånd (se øverste billede)
- Kundetilpasset understel
- Hjul (2 faste / 2 drejelige)

Varianter

- R 608 – 600 mm bredt x 8 valser
- R 908 – 900 mm bredt x 8 valser
- R 1210 – 1.200 mm bredt x 10 valser
- R 1510 – 1.500 mm bredt x 10 valser



A/S Skals Maskinfabrik
Hovedgaden 56 • DK-8832 Skals
tlf. +45 87 25 62 00 • fax. +45 86 69 49 99
skals@skals.dk • www.skals.dk • CVR / VAT 17 21 80 18



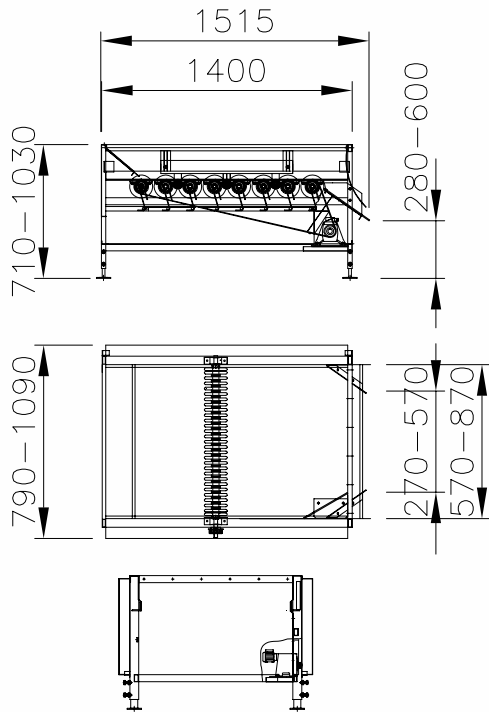

R608-908

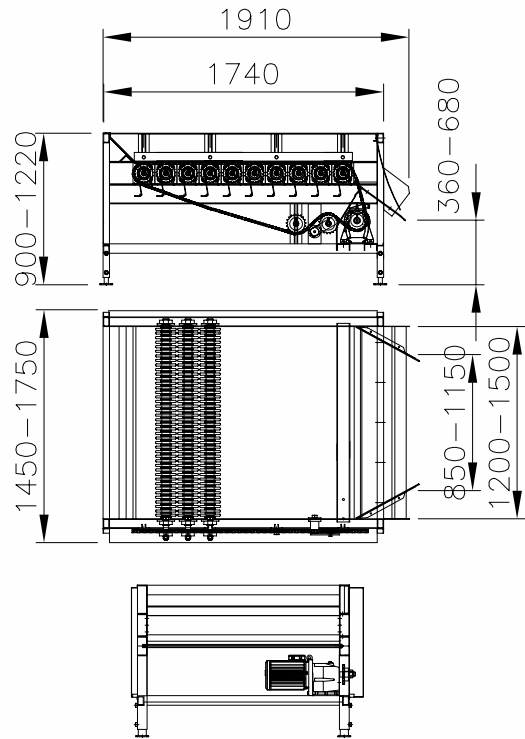

R1210-1510

TYPE	R608	R908	R1210	R1510
Kapacitet, Capacity, Kapazität	8 tons/h	13 tons/h	30 tons/h	40 tons/h
Rensebredde, Cleaning width, Breite der Walzen	540 mm	840 mm	1140 mm	1440 mm
Antal valser, No of rollers, Anzahl der Walzen	8	8	10	10
Motor	0,75 kW	1,1 kW	2,2 kW	3,0 kW
Vægt, Weight, Gewicht	225 kg	270 kg	480 kg	720 kg

	производительность	ширина роликов	кол-во роликов	мотор
R 608	до 12 тн/час	600	8	0,75 кВт
R 908	до 18 тн/час	900	8	1,1 кВт
R 1210	до 30 тн/час	1200	10	2,2 кВт
R 1510	до 40 тн/час	1500	10	3,0 кВт