

## Evenflow

Type: ABF 1025-1425-1825

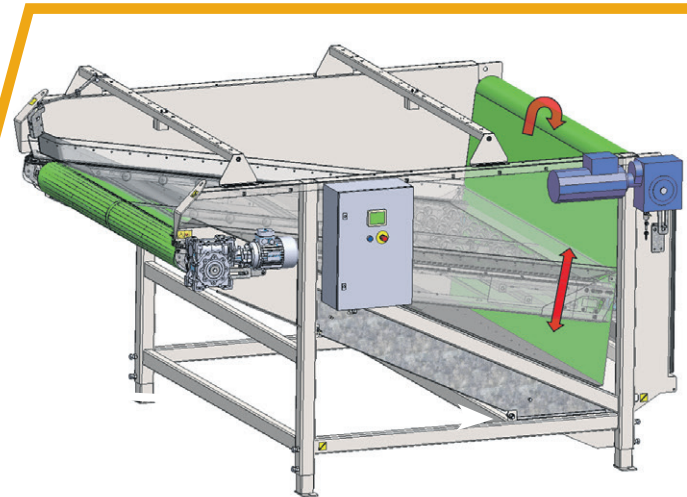

## Optimized operation and less flow stops



Variant	Conveyor width	Container width	M <sup>3</sup>
ABF 1825	1800	2000	3
ABF 1425	1400	1600	2,4
ABF 1025	1000	1200	1,8

## Functions

- Continuous flow in full width ensures a capacity increment of 30% on graders by implementation of an Even Flow feeder
- Flow regulation optimizes line processes and reduces flow stops
- The inlet end of the belt is vertically adjusted 1 m to minimize drop height and optimized buffer capacity.
- Integration of Even flow creates independence between machines
- Automatic speed regulation ensures constant flow based on level sensor
- Remote controlled flow adjustment. (Optional)
- Version for carrots with cleats on the belt is available (Optional)
- Top mounted box tippler ensures optimal line feed with boxes (Optional)



