

SKALS

- we'll sort it out!

Buffer

Type: ABM 430 / ABM 630



Gentle buffer to even the flow



Functions

- Internally covered w. damping materials
- Displaced cleats for even flow
- Prepared for SKALS box tipper
- Adjustable belt speed via variator
- Constructed in galvanised plating

Options

- Customized conveyor length
- Superstructure of 400 mm for add. capacity
- Pressure relief above the belt
- Frequency converter
- Fall damper straps for gentle box tipping

Variants

- ABM 430 – 400 mm wide belt
- ABM 630 – 600 mm wide belt



A/S Skals Maskinfabrik
Hovedgaden 56 • DK-8832 Skals
tlf. +45 87 25 62 00 • fax. +45 86 69 49 99
skals@skals.dk • www.skals.dk • CVR / VAT 17 21 80 18



ABM430

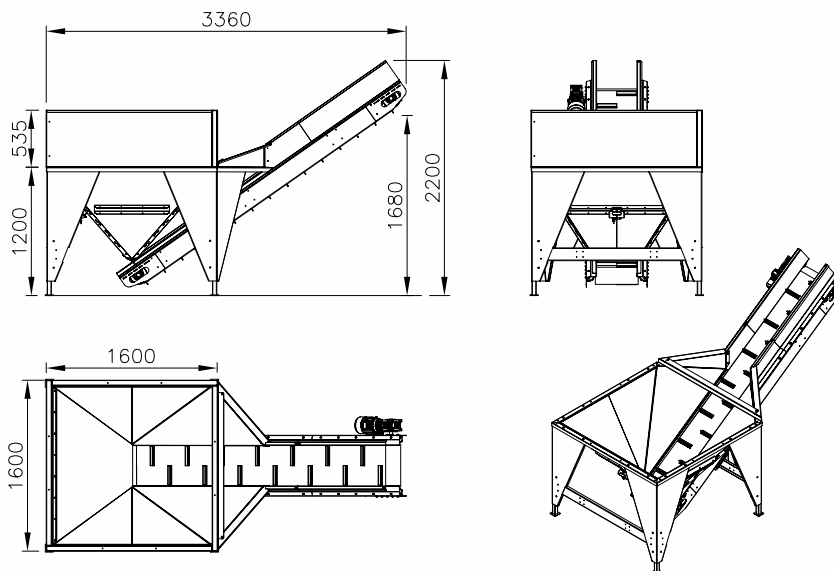

ABM630

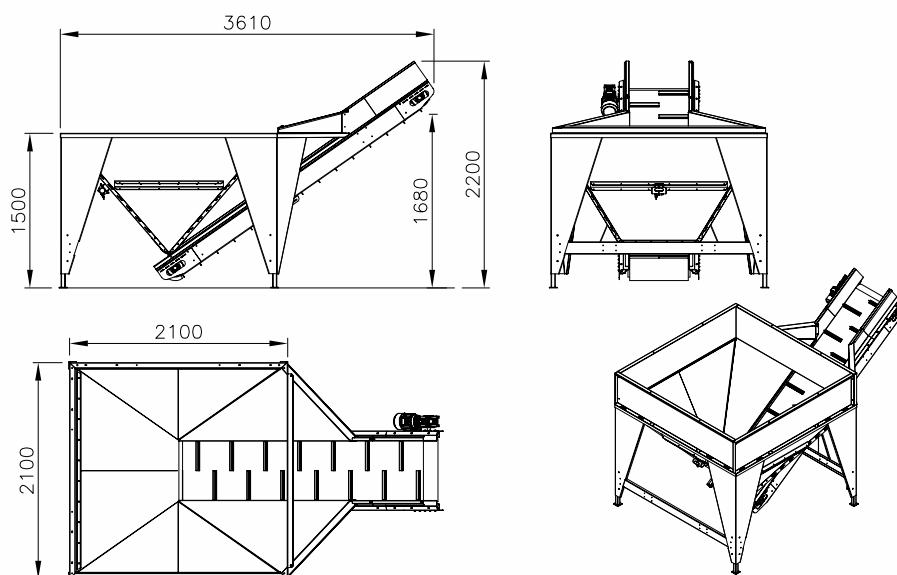

	AMB430	ABM630
Kapacitet, Capacity, Stundenleistung	2 - 10 t/h	4 - 20 t/h
Volumen, uden overb. Without superst. Ohne Überbau	0,65 m ³	1,5 m ³
Volumen, overb.,superst.,Überbau	1,35 m ³	1,9 m ³
Båndbr. Belt width, Bandbreite	400 mm	600 mm
Båndlængde, Belt length, Bandlänge	3100 mm	3100 mm
Båndhast., Belt speed, .Bandgeschwindigkeit	0,03 - 0,14 m/s.	0,03 - 0,14 m/s.
Motor.	0,37 kW.	0,75 kW.

тип машины	ABM 430	ABM 630
производительность	2 – 10 тн/час	4 – 20 тн/час
объем	0,65 м ³	1,5 м ³
ширина трансп. ленты	400 мм	600 мм
длина элеватора	3000 мм	3000 мм
скорость элеватора	0,03 – 0,14 м/с	0,03 – 0,14 м/с
мотор	0,37 кВт	0,75 кВт