

# SKALS

- we'll sort it out!

## Buffer silo w. 2 outlets

Type: AV 418-2



## Effective filling of big bags

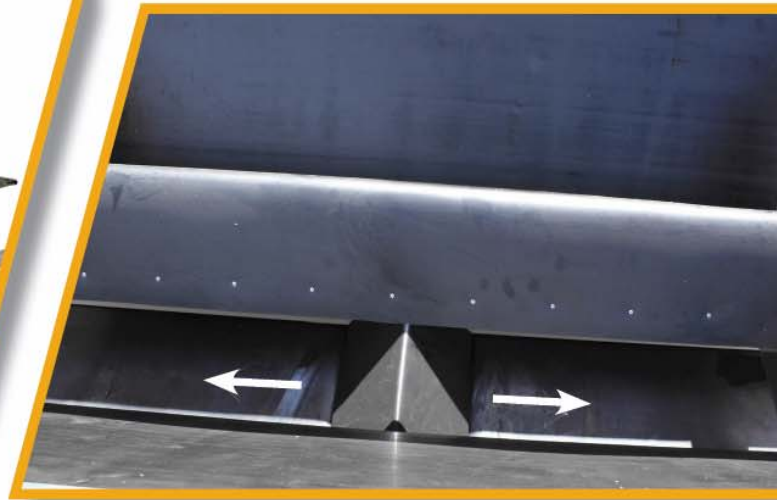

### Functions

- 2 outlets / bag holders = double packing capacity
- Contains w. 1 superstructure approx. 1.000 kg.
- Plug and play w. electricity and foot pedals
- Internal rubber eliminates product damages
- Continuously variable belt speed via variator
- Outlet shutter for outlet flow control
- Pressure relief above the belts
- Belt scrapers for keeping the belts clean

### Options

- Superstructure ( 500 mm ) for add. volume
- Fall damping straps for gentle box tipping
- Stainless version

### Variants

- AV 418 – 400 mm wide belts – 1,8 m long
- AV 418-2 – AV418 w. 2 outlets for bagging



A/S Skals Maskinfabrik  
Hovedgaden 56 • DK-8832 Skals  
tlf. +45 87 25 62 00 • fax. +45 86 69 49 99  
skals@skals.dk • www.skals.dk • CVR / VAT 17 21 80 18



## AV418-2

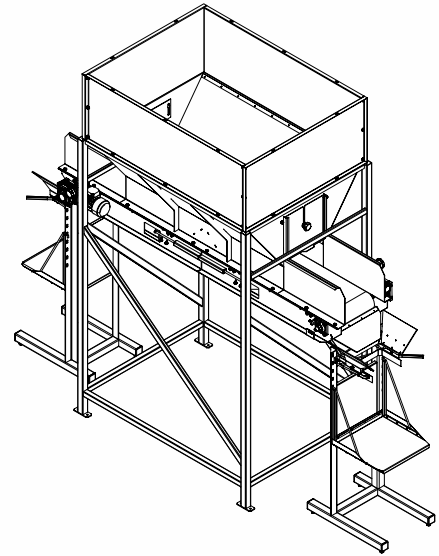
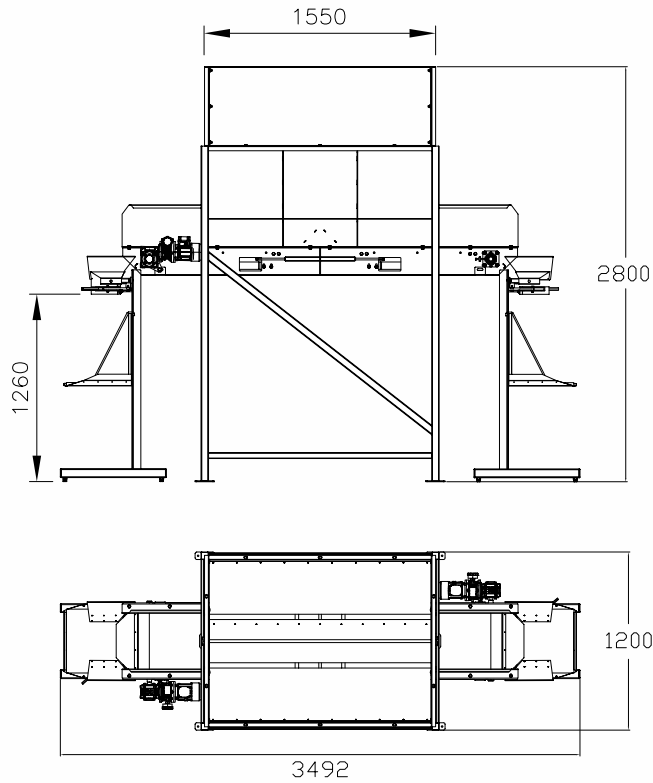

<b>Kapacitet, Capacity, Leistung</b>	1,4 - 10 t/h
<b>Volumen, uden overb. without superst. ohne Überbau</b>	0,6 m <sup>3</sup>
<b>Volumen, overb., superst.,Überbau</b>	0,9 m <sup>3</sup>
<b>Båndbr. Belt width, Bandbreite</b>	400 mm
<b>Båndlængde, Belt length, Bandlänge</b>	2x1200 mm
<b>Siloramme, Silo frame, Silo Rahmen</b>	1200 x 1600
<b>Båndhast., Belt speed, .Bandgeschwindigkeit</b>	0,015-0,075 m/s.
<b>Motor.</b>	2x0,22 kW.

производительность	объем	объем/суперстр.	транспортер	мотор
1,4 – 10 тн/час	0,6 м <sup>3</sup>	0,9 м <sup>3</sup>	2x400x1200	2x0,22 кВт