

Manual

Afvejningsplatform

AP

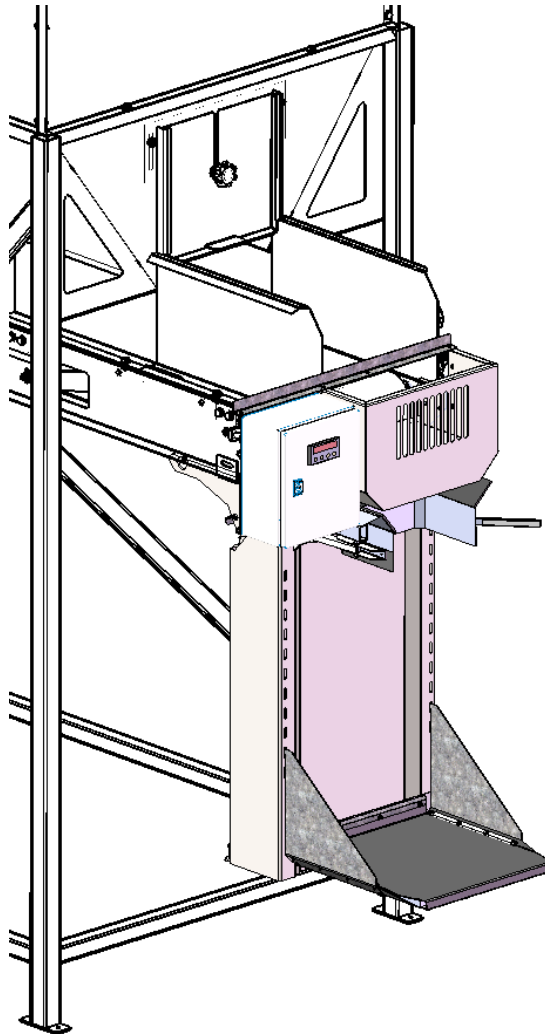

A/S SKALS MASKINFABRIK
HOVEDGADEN 56
DK-8832 SKALS, DANMARK
Tlf.: +45 87 25 62 00
Fax: +45 86 69 49 99
E-mail: Skals@skals.DK
<http://www.skals.DK/>



1	Indhold	
2	Introduktion	2
3	Sikkerhed	3
4	Generelt	3
5	Drift	4
5.1	Opstilling.....	4
5.2	El tilslutning	4
5.3	Service og vedligeholdelse.....	6
5.4	Rengøring.....	6
6	Fejlfinding	7
6.1	Fejl beskrevet i display.	Fejl! Bogmærke er ikke defineret.
7	Reservedelsliste	8
8	EU Overenstemmelseserklæring	12

2 Introduktion

Læs denne brugsanvisning grundigt inden ibrugtagning.

Maskinen anvendes til afvejning af kartofler, løg, gulerødder og lignende produkter.
Maskinen kan afveje portionsstørrelser fra 1 - 150 kg.

Maskinen kan arbejde indenfor et temperaturområde fra -10 til +40 C.

Typeskilt og CE mærke er placeret på siden af maskinen, tæt ved styreskabet.

3 Sikkerhed

Vejeplatformen er som standard monteret på en anden maskine. Sikkerhedsforskrifterne for denne maskine skal altid følges

Personer der arbejder tæt ved maskinen må ikke bære løstsiddende tøj da dette kan være til fare for deres sikkerhed

4 Generelt

Beskrivelse af maskinen

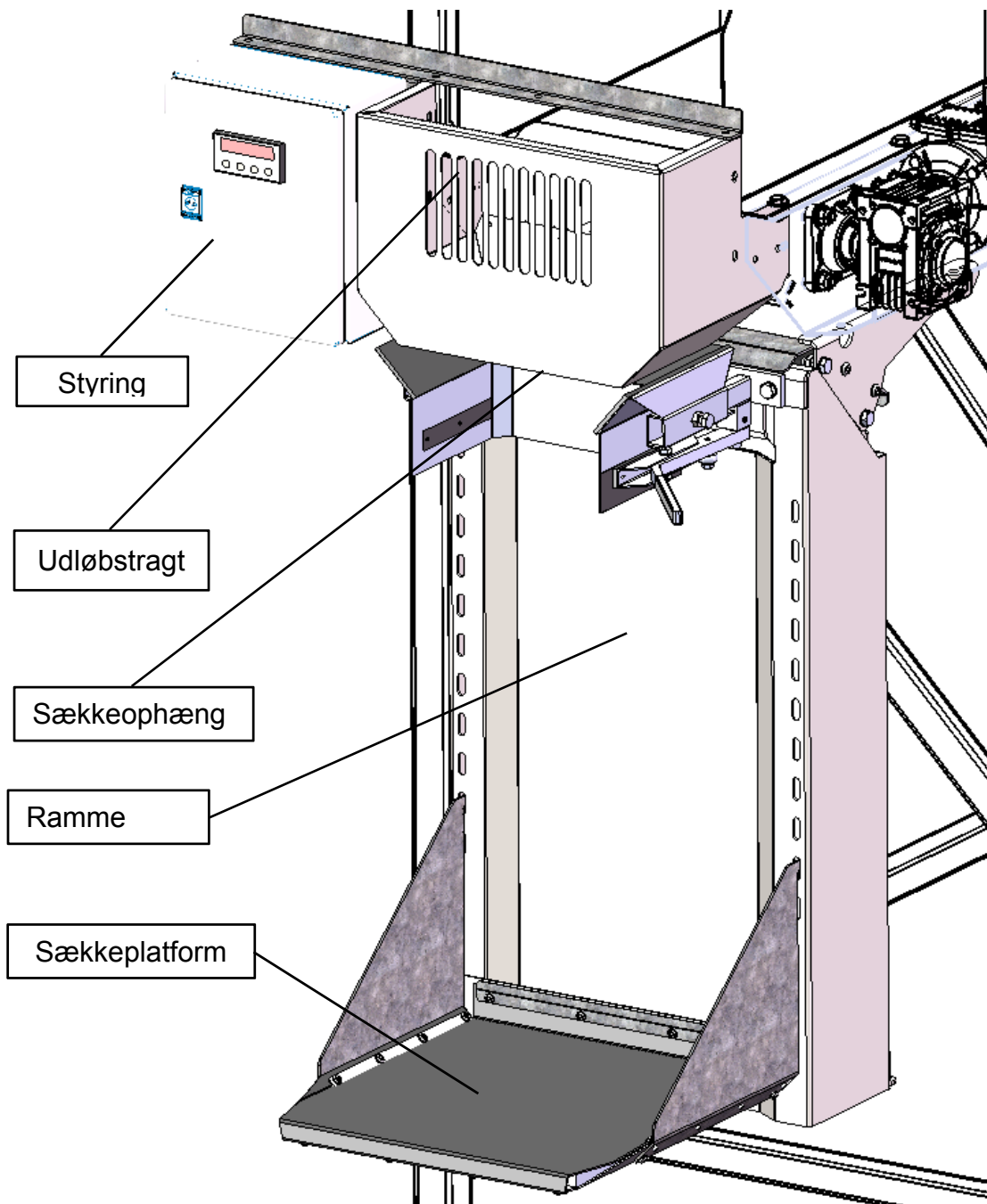

5 Drift

Før maskinen tages i brug skal den efterses for skader der kan være opstået under transport.

eventuelle fejl oplyses straks til forhandleren.

5.1 Opstilling

Det er vigtigt at maskinen, som vejeplatformen er monteret på, er placeret på et stabilt og jævnt underlag for at opnå rigtig afvejning.

5.2 El tilslutning

skal ske i henhold til landets gældende regulativ.

1Fase 230V - N + PE

5.3 Styling

Beskrivelse af taster:



For at annullere og vende tilbage til den forrige menu.



For at ændre den viste værdi eller menupunkt.



For at vælge en ny værdi eller ændre den viste menupunkt.



For at indtaste en menu eller bekræfte indtastning af data.

Kalibrering af vægt

Start altid med at displayet viser tryk til dette er tilfældet.
Placer en kendt vægt på platformen(eks.50 kg) og tryk følgende



→



→



indtil displayet viser



Displayet viser muligvis 49,8kg Dette ændres til den præcise last der er placeret på platformen (50,0kg)



for at godkende kalibreringen.



indtil vises i displayet

Vægten er nu kalibreret og klar til afvejning.

Indstilling af vægt

Start altid med at displayet viser tryk til dette er tilfældet.



→



→



→



→

Indstil vægt(eks. 48,0kg)



→



→

Indstil vægt(eks. 50,0kg)



indtil displayet viser

Vægten er klar til afvejning af 50kg sække (dosering starter v. 48kg)

(Set 03, Set 04, Set 05) Bruges ikke

Der findes en mere udførlig beskrivelse af veje indikatoren bagerst i denne manual

5.4 Service og vedligeholdelse

Under service og vedligeholdelse må maskinen ikke være tilsluttet el nettet.

Maskinen skal efterspændes efter de første 20 timers drift og herefter efterspændes efter behov.

OBS: Tilspændingsmoment for boltene i vejecellen er 16Nm.

5.5 Rengøring

Der bør foretages daglig rengøring af området mellem udløbstragt og sækkeophæng for at sikre korrekt vejning.

Ved højtryksrensning må der ikke spules direkte på vejecelle og styring.

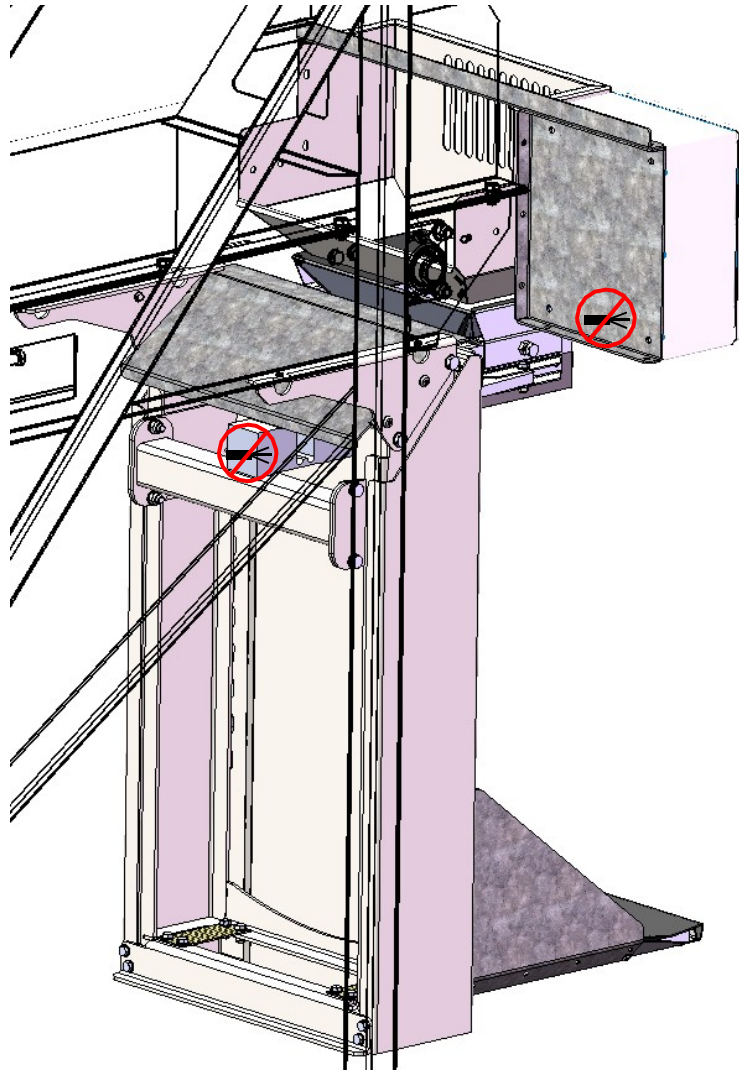

6 Fejlfinding

OBS: når der arbejdes med de mekaniske dele skal maskinen ALTID slukkes på hovedafbryderen.

7 Reservedelsliste

Ved bestilling af reservedele angives maskintype, serie nr. og evt. varenummer.

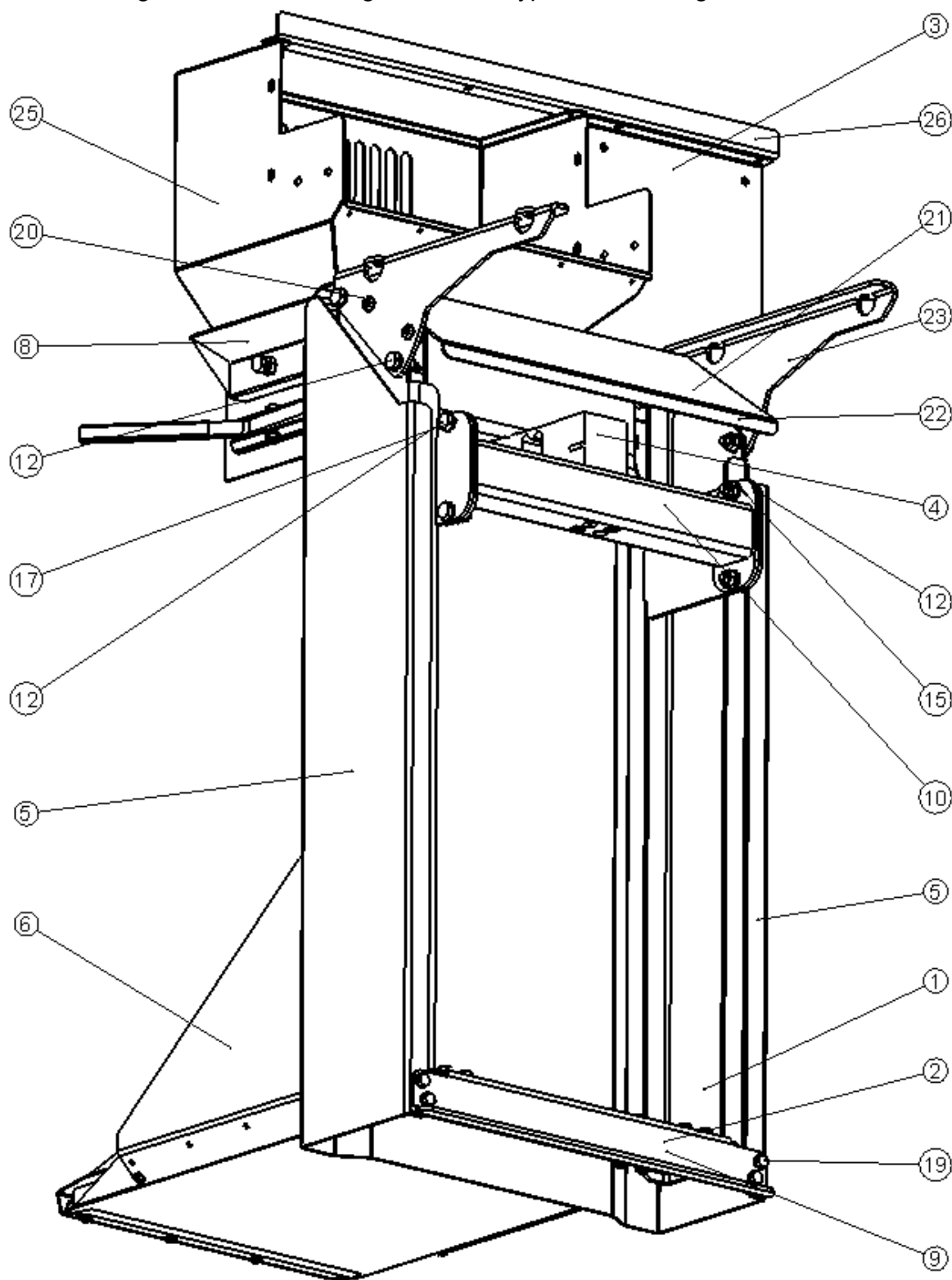

NO.	QTY.	PART NO.	DESCRIPTION	MATERIAL	Description GB
1	1	60001198	Bagramme svejst	Svejsesamling	Frame
2	2	16115418	Composit fjeder til vægt ophæng	S-PLY	Spring
3	1	60001203	Styring til afvejningsplatform	Samling	control cabinet
4	1	10086017	VEJECELLE 1263 TII AP50	Aluminium	Loadcell
5	1	60001201	Frontramme svejst	Svejsesamling	Frame
6	1	60000334	Sækkeplatform samlet	Samling	Platform
7	1	32620251	Sækkeholder for AM315 50kg	Samling	Bag holder
8	1	22835014	Udløbstud stor	Samling	Outlet, big
9	1	60001204	Plade 3 til forramme galv.	5mm. stålblade Domex 240 el. tilsv.	Bracket
10	1	60001202	Tværprofil til vejecelle svejst	Svejsesamling	Profile
11	8	16926171	Unbracoskrue CH M8x12		Bolt
12	8	16910318	Stålsætskrue M10x30	8,8 Elforz. HFC 473	Bolt
13	2	16910320	Stålsætskrue M10x35	8,8 Elforz. HFC 473	Bolt
14	32	17095066	Skive M8 Facet	HFC 9167 8.8 Elforz.	Washer
15	19	17095068	Skive M10 Facet	HFC 9167 8.8 Elforz.	Washer
16	8	17160008	SKIVE Ø8 Centerfjeder STÅL Z DIN 128		Lock washer
17	10	17000064	Låsemøtrik M10	HFC 840 ELFORZ.	Nut
18	12	17000062	Låsemøtrik M8	HFC 840 ELFORZ.	Nut
19	12	16910258	Stålsætskrue M8x20	8,8 Elforz. HFC 473	Bolt
20	4	16761817	Gevindform. skrue M8x12	Torx, 7516T080162	Screw
21	1	20003494	L/B Skærm over vejecelle	3mm Galv. stålblade	Sheet over loadcell
22	1	20003493	L/B Plade bag styreskab	3mm Galv. stålblade	Sheet
23	1	60001205	Oph. mellem AP & AV418 h/v galv.	5mm stålblade Domex 240 el. tilsv.	Bracket
24	1	60001205	Oph. mellem AP & AV418 h/v galv.	5mm. stålblade Domex 240 el. tilsv.	Bracket
25	1	60001199	Udløbstud sv.	Svejsesamling	Outlet
26	1	20003492	L/B Vinkel over styreskab	3mm Galv. stålblade	angle bracket

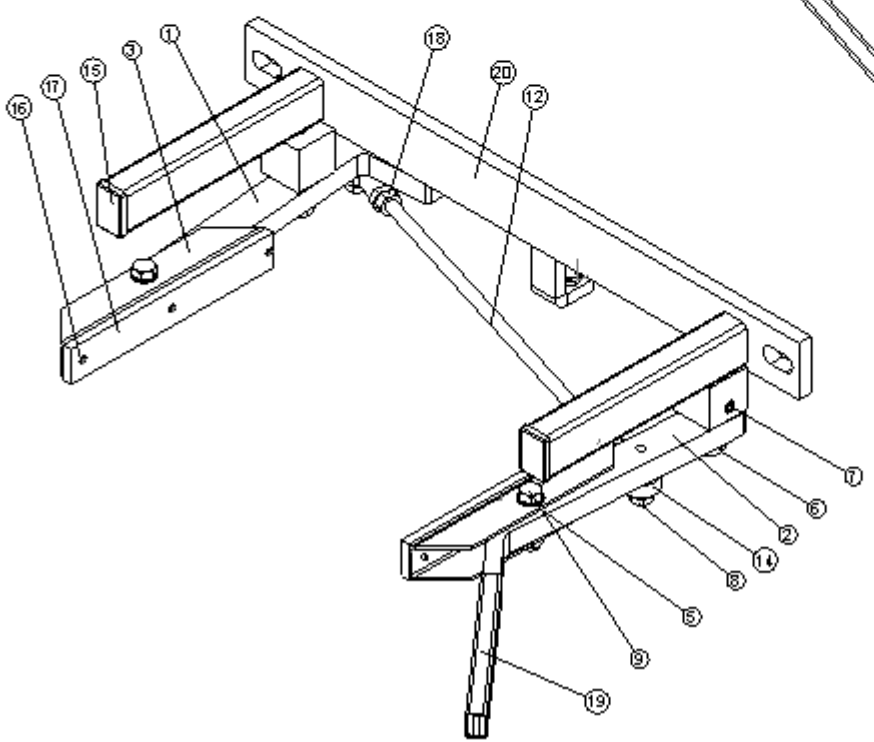
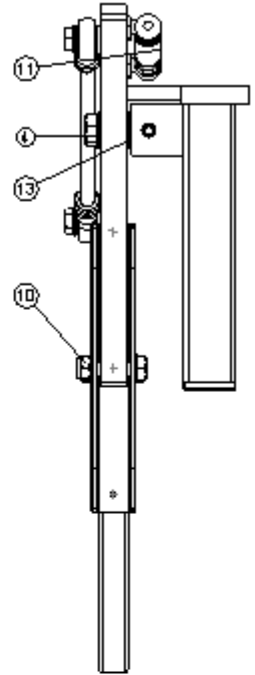
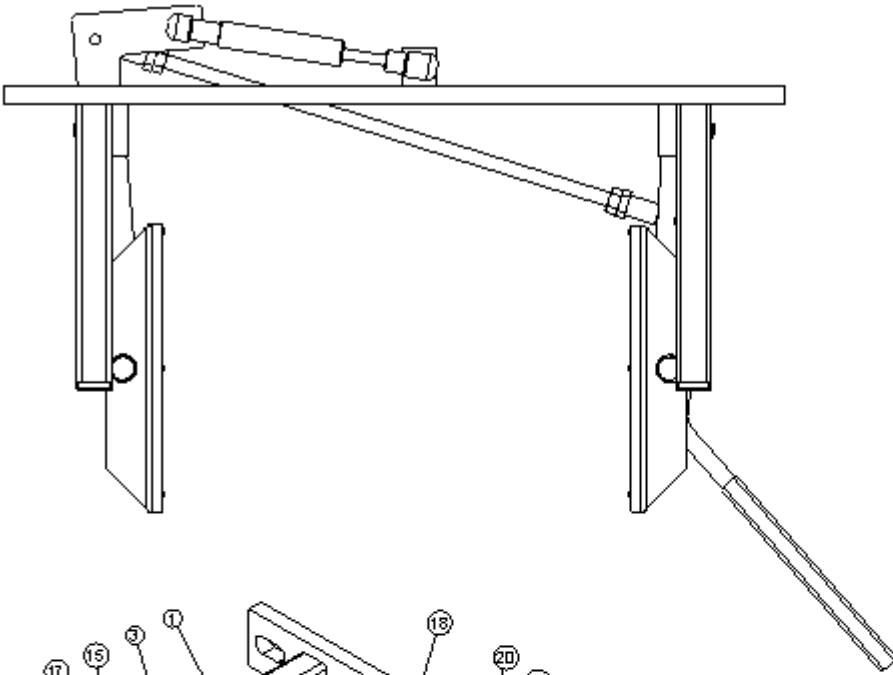

NO.	QTY.	PART NO.	DESCRIPTION	MATERIAL	Description GB
1	1	20000052	L/B Klemarm for sækkeholder	15mm. stålplade Domex 240 el. tilsv. 215x75	Arm
2	1	20000053	L/B Håndtag for sækkeholder	15mm. stålplade Domex 240 el. tilsv. 319x151	Arm
3	2	56000604	L/B Sækkeholdere	2mm. varmgalvaniseret stålplade: 165x70	Bracket
4	4	17095068	Skive M10 Facet	HFC 9167 8.8 Elforz.	Washer
5	8	17095066	Skive M8 Facet	HFC 9167 8.8 Elforz.	Washer
6	2	16910322	Stålsætskrue M10x40	8,8 Elforz. HFC 473	Bolt
7	2	16920184	Pinolskrue M8x12	HFC 710	Screw
8	2	16910262	Stålsætskrue M8x30	8,8 Elforz. HFC 473	Bolt
9	2	16910264	Stålsætskrue M8x35	8,8 Elforz. HFC 473	Bolt
10	2	17000062	Låsemøtrik M8	HFC 840 ELFORZ.	Nut
11	1	16125020	Gasfjeder 1338DJ		gas cylinder
12	1	20000078	Gevindstang	Gevindstang M8 4,6 elforz. x310	threaded rod
13	2	15065300	Plastikbøsning ø14/19 hul 10	Type K134	Bush
14	2	15420020	Leje PHS8A kugleled		Bearing
15	2	15871040	Rørben 30x20x2 RHS	Plast	Legs
16	6	16100300	Popnitte 3,2x10 stål		Pop rivets
17	2	20000079	Supergrib f. sækkeholder	Supergrib	Supergrip
18	2	16970090	Møtrik M8	HFC 9832	Nut
19	1	20000080	Slange for håndtag	PVC ø16/21mm.	Handle
20	1	32620252	Sækkeholder svejst	Samling	Bag holder

8 EU Overensstemmelseserklæring

Fabrikant:	
Firmanavn:	A/S Skals maskinfabrik
Adresse:	Hovedgaden 56
	8832 Skals
Telefon:	+45 87256200

Erklærer hermed at

Maskine:	Afvejningsplatform
Type:	AP50
Type, serie nr., år:	

Er fremstillet i overensstemmelse med:

1. Maskinsikkerhed – Direktiv 2006/42/EF
2. Lavspændingsdirektivet (LVD) 2006/95/EEC
3. Elektromagnetisk kompatibilitet (EMC) Direktiv 89/336/EEC og den tilrettede 93/68/EEC.

Titel:	Produktions manager
Navn:	Søren Lund Madsen
Firma:	A/S Skals maskinfabrik

Dato _____ Signatur



ENGLISH



ENGLISH



ENGLISH



ENGLISH

Installation and User Manual

versione 1.04

W100 – W100ANA



 2004/108/EC

EN55022 EN61000-6-2 EN61000-6-4

SYSTEM IDENTIFICATION

For internal use only

KEY TO SYMBOLS

Below are the symbols used in the manual to draw the reader's attention:



Caution! High Voltage.



Caution! This operation must be performed by skilled workers.



Read the following indications carefully.



Further information.

Disposal of Waste Equipment by Users in Private Households in the European Union



This symbol on the product or on its packaging indicates that this product must not be disposed of with your other household waste. Instead, it is your responsibility to dispose of your waste equipment by handing it over to a designated collection point for the recycling of waste electrical and electronic equipment. The separate collection and recycling of your waste equipment at the time of disposal will help preserve natural resources and protect human health and the environment. For more information about where you can drop off your waste equipment for recycling, please contact your local waste disposal Authority or the equipment retailer.

TABLE OF CONTENTS

USER WARNINGS	1
RECOMMENDATIONS FOR CORRECT INSTALLATION OF WEIGHING INSTRUMENTS .	1
RECOMMENDATIONS FOR CORRECT INSTALLATION OF THE LOAD CELLS	1
LOAD CELL INPUT TEST (QUICK ACCESS)	3
LOAD CELL TESTING	3
MAIN SPECIFICATIONS OF THE INSTRUMENT	4
BUFFER BATTERY	4
TECHNICAL SPECIFICATIONS	5
ELECTRICAL CONNECTIONS	6
BASIC INFORMATIONS	6
WIRING DIAGRAM	7
LED AND KEY FUNCTIONS	8
MENU MAP	9
SETPOINTS	9
SYSTEM PARAMETERS	9
INSTRUMENT COMMISSIONING	10
PROGRAMMING OF SYSTEM PARAMETERS	11
THEORETICAL CALIBRATION	11
<i>MAXIMUM CAPACITY</i>	12
<i>TARE WEIGHT ZERO SETTING</i>	12
<i>ZERO VALUE MANUAL ENTRY</i>	12
REAL CALIBRATION (WITH SAMPLE WEIGHTS)	13
FILTER ON THE WEIGHT	14
ZERO PARAMETERS	14
<i>RESETTABLE WEIGHT SETTING FOR SMALL WEIGHT CHANGES</i>	14
<i>AUTOMATIC ZERO SETTING AT POWER-ON</i>	15
<i>ZERO TRACKING</i>	15
SETTING UNITS OF MEASURE	15
<i>DISPLAY COEFFICIENT</i>	15
OUTPUTS AND INPUTS CONFIGURATION	17
SEMI-AUTOMATIC TARE (NET/GROSS)	18
PRESET TARE (SUBTRACTIVE TARE DEVICE)	19
SEMI-AUTOMATIC ZERO (WEIGHT ZERO-SETTING FOR SMALL VARIATIONS)	19
PEAK	19
ANALOG OUTPUT (ONLY FOR INSTRUMENTS WHERE THIS OPTION IS AVAILABLE) .	20
SERIAL COMMUNICATION SETTINGS	22
<i>RS232 SERIAL COMMUNICATION</i>	23
<i>RS485 SERIAL COMMUNICATION</i>	24
<i>DIRECT CONNECTION BETWEEN RS485 AND RS232 WITHOUT CONVERTER</i>	24
TEST	25
DATE AND TIME SETTING	25

SETPOINTS PROGRAMMING.....	26
ALARMS.....	26
PRINTING EXAMPLES	28
RESERVED FOR THE INSTALLER	29
MENU LOCKING	29
MENU UNLOCKING.....	29
TEMPORARY MENU UNLOCKING.....	29
PROGRAM SELECTION AND DATA DELETION.....	29
KEYPAD OR DISPLAY LOCKING	30
DECLARATION OF CONFORMITY 	31

USER WARNINGS

RECOMMENDATIONS FOR THE PROPER USE OF WEIGHING INSTRUMENT

- Keep away from heat sources and direct sunlight
- Repair the instrument from rain (except special IP versions)
- Do not wash with water jets (except special IP versions)
- Do not dip in water
- Do not spill liquid on the instrument
- Do not use solvents to clean the instrument
- Do not install in areas subject to explosion hazard (except special Atex versions)

RECOMMENDATIONS FOR CORRECT INSTALLATION OF WEIGHING INSTRUMENTS

The terminals indicated on the instrument's wiring diagram to be connected to earth must have the same potential as the weighed structure (same earthing pit or earthing system). If you are unable to ensure this condition, connect with an earthing wire the terminals of the instrument (including the terminal – SUPPLY) to the weighed structure.

The cell cable must be individually led to its panel input and not share a conduit with other cables; connect it directly to the instrument terminal strip without breaking its route with support terminal strips.

Use "RC" filters on the instrument-driven solenoid valve and remote control switch coils.

Avoid inverters in the instrument panel; if inevitable, use special filters for the inverters and separate them with sheet metal partitions.

The panel installer must provide electric protections for the instruments (fuses, door lock switch etc.).

It is advisable to leave the equipment always switched on to prevent the formation of condensation.

MAXIMUM CABLE LENGTHS

- RS485: 1000 metres with AWG24, shielded and twisted cables
- RS232: 15 metres for baud rates up to 19200
- Analog current output: up to 500 metres with 0.5 mm² cable
- Analog current output: up to 300 metres with 0.5 mm² cable

RECOMMENDATIONS FOR CORRECT INSTALLATION OF THE LOAD CELLS

INSTALLING LOAD CELLS: The load cells must be placed on rigid, stable in-line structures; it is important to use the mounting modules for load cells to compensate for misalignment of the support surfaces.

PROTECTION OF THE CELL CABLE: Use water-proof sheaths and joints in order to protect the cables of the cells.

MECHANICAL RESTRAINTS (pipes, etc.): When pipes are present, we recommend the use of hoses and flexible couplings with open mouthpieces with rubber protection; in case of hard pipes, place the pipe support or anchor bracket as far as possible from the weighed structure (at a distance at least 40 times the diameter of the pipe).

CONNECTING SEVERAL CELLS IN PARALLEL: Connect several cells in parallel by using - if necessary - a watertight junction box with terminal box. The cell connection extension cables must be shielded, led individually into their piping or conduit and laid as far as possible from the power cables (in case of 4-wire connections, use cables with 4 x 1 sq.mm minimum cross-section).

WELDING: Avoid welding with the load cells already installed. If this cannot be avoided, place the welder ground clamp close to the required welding point to prevent sending current through the load cell body.

WINDY CONDITIONS - KNOCKS - VIBRATIONS: The use of weigh modules is strongly recommended for all load cells to compensate for misalignment of the support surfaces. The system designer must ensure that the plant is protected against lateral shifting and tipping relating to: shocks and vibration; windy conditions; seismic conditions in the installation setting; stability of the support structure.

EARTHING THE WEIGHED STRUCTURE: By means of a copper wire with suitable cross-section, connect the cell upper support plate with the lower support plate, then connect all the lower plates to a single earthing system. Electrostatic charges accumulated because of the product rubbing against the pipes and the weighed container walls are discharged to the ground without going through or damaging the load cells. Failure to implement a proper earthing system might not affect the operation of the weighing system; this, however, does not rule out the possibility that the cells and connected instrument may become damaged in the future. It is forbidden to ensure earthing system continuity by using metal parts contained in the weighed structure.

**FAILURE TO FOLLOW THE INSTALLATION RECOMMENDATIONS WILL BE CONSIDERED
A MISUSE OF THE EQUIPMENT**

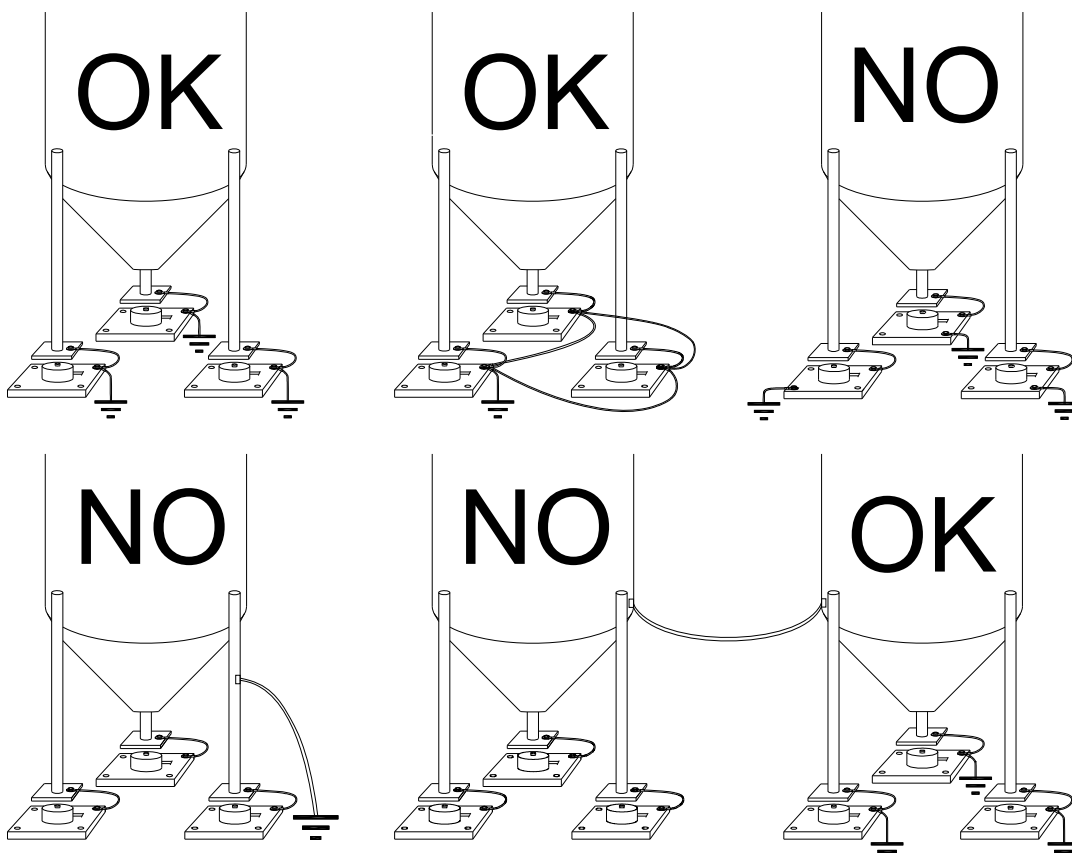

LOAD CELL INPUT TEST (QUICK ACCESS)

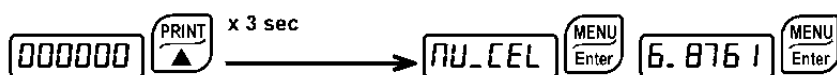

From the weight display, press  for 3 seconds; the response signal of the load cells is displayed, expressed in mV with four decimals.

LOAD CELL TESTING

Load cell resistance measurement (use a digital multimeter):

- Disconnect the load cells from the instrument and check that there is no moisture in the cell junction box caused by condensation or water infiltration. If so, drain the system or replace it if necessary.
- The value between the positive signal wire and the negative signal wire must be equal or similar to the one indicated in the load cell data sheet (output resistance).
- The value between the positive excitation wire and the negative excitation wire must be equal or similar to the one indicated in the load cell data sheet (input resistance).
- The insulation value between the shield and any other cell wire and between any other cell wire and the body of the load cell must be higher than 20 Mohm (mega ohms).

Load cell voltage measurement (use a digital multimeter):

- Take out the load cell to be tested from underneath the container, or alternatively, lift the container support.
- Make sure that the excitation of two wires of the load cell connected to the instrument (or amplifier) is 5 Vdc +/- 3%.
- Measure the response signal between the positive and the negative signal wires by directly connecting them to the tester, and make sure that it is comprised between 0 and 0.5 mV (thousandths of a Volt).
- Apply load to the cell and make sure that there is a signal increment.

IF ONE OF THE ABOVE CONDITIONS IS NOT MET, PLEASE CONTACT THE TECHNICAL ASSISTANCE SERVICE.

MAIN SPECIFICATIONS OF THE INSTRUMENT

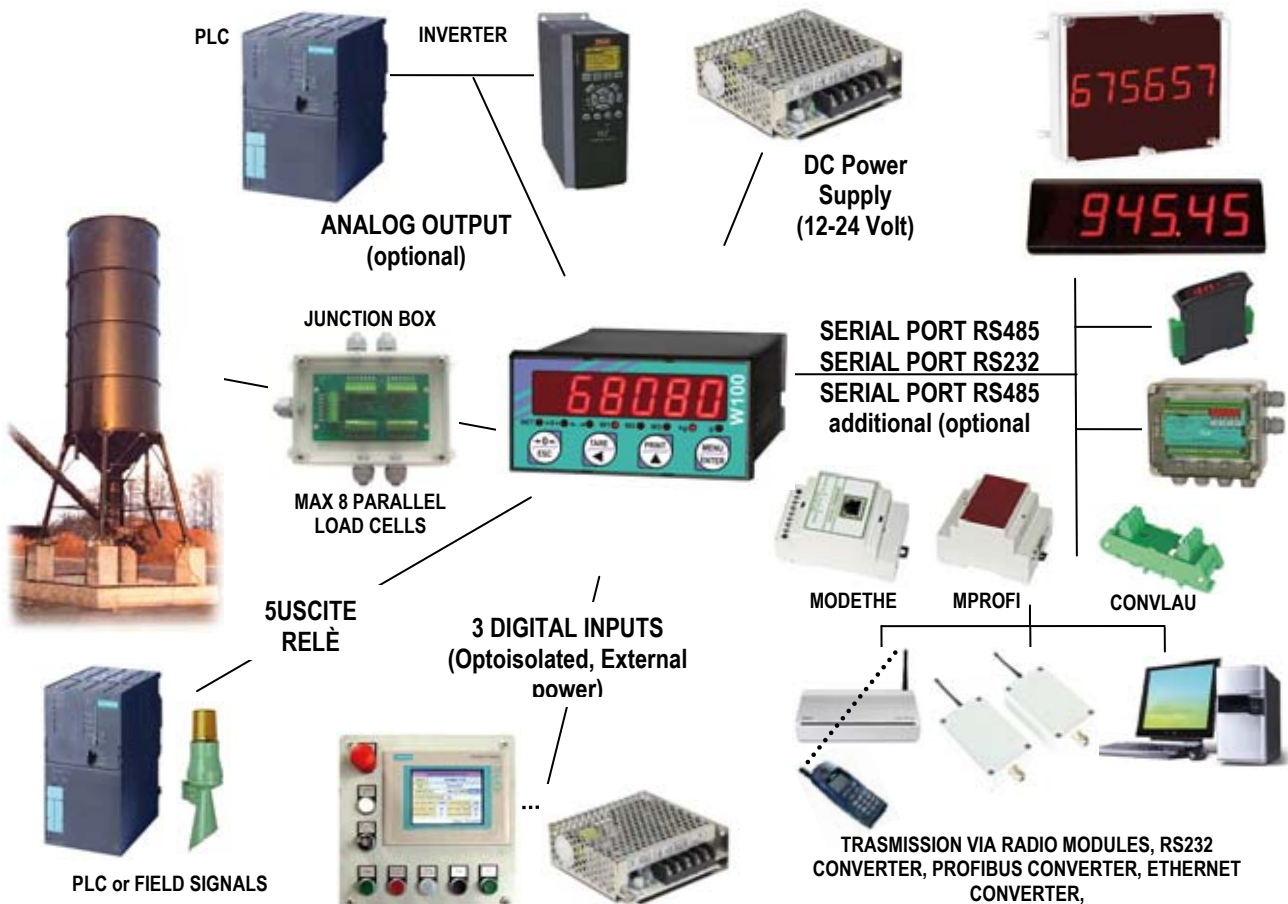

- Indicator with 6-wire load cell input in DIN box (48x96x130 mm; drilling template 45x91mm) for panel front mounting. Front panel protection rating IP54 (IP65 front optional). 6-digit semialphanumeric display, 14 mm, 7 segments; 8 indicator LEDs. 4-key membrane keypad with buzzer. Real-time clock/calendar with buffer battery.
- It is possible to print: current date and time, net/gross weight, peak, ID (if the alibi memory is active) and preset tare.
- The instrument is equipped with two serial ports, RS485 and RS232, for connection to:
 - PC/PLC through ASCII or Modbus R.T.U. protocol (optional protocols: Profibus DP and Ethernet/Modbus TCP);
 - weight remote display;
 - printer.
- Transmits the gross or net weight via RS485 and RS232 serial ports.

BUFFER BATTERY

The instrument is equipped with an internal battery that allows to keep active the internal clock even in the event of power failure.



At the first start and after long periods of inactivity, leave the instrument on for at least 12 hours to fully charge the battery.

TECHNICAL SPECIFICATIONS

POWER SUPPLY and CONSUMPTION (VDC)	12 - 24 VDC (standard) +/- 10%; 5 W
NO. OF LOAD CELLS IN PARALLEL and SUPPLY	max 8 (350 Ohm) ; 5VDC/120mA
LINEARITY / ANALOG OUTPUT LINEARITY	< 0.01% F.S. ; < 0.01% F.S.
THERMAL DRIFT / ANALOG OUTPUT THERMAL DRIFT	< 0.0005 % F.S. /°C ; < 0.003 % F.S./°C
A/D CONVERTER	24 bit (16.000.000 points)
MAX DIVISIONS (with measurement range: +/-10mV = sens. 2mV/V)	+/- 999999
MEASUREMENT RANGE	+/- 39 mV
MAX SENSITIVITY OF USABLE LOAD CELLS	+/-7mV/V
MAX CONVERSIONS PER SECOND	300 conversions/second
DISPLAY RANGE	- 999999 ; + 999999
NO. OF DECIMALS / DISPLAY INCREMENTS	0 - 4 / x 1 x 2 x 5 x 10 x 20 x 50 x 100
DIGITAL FILTER / READINGS PER SECOND	0.012 – 7 sec / 5 - 300 Hz
RELAY LOGIC OUTPUTS	N.5 - max 115 VAC ; 150mA (N. 4 – Analog output model)
LOGIC INPUTS	N.3 - optoisolati 5 - 24 VDC PNP (N. 2 – Analog output model)
SERIAL PORTS	RS485, RS232
BAUD RATE	2400, 4800, 9600, 19200, 38400, 115200
HUMIDITY (non condensing)	85 %
STORAGE TEMPERATURE	- 30°C + 80°C
WORKING TEMPERATURE	- 20°C + 60°C
OPTICALLY ISOLATED ANALOG OUTPUT (OPTIONAL) 16 Bit - 65535 divisions	0-20 mA; 4-20 mA (300 ohm max); 0-10 Vdc; 0-5 Vdc; +/- 10 Vdc; +/- 5 Vdc (10 kohm min).

ELECTRICAL CONNECTIONS

TERMINALS LEGEND

1	+ SUPPLY (12-24 VDC)	13	
2	- SUPPLY (12-24 VDC) GROUND RS232: SHIELD; GND E\EC OPTION	14	INPUT No 3 (+VDC min 5V max 24V) <i>otherwise:</i> + ANALOG OUTPUT 0-20 o 4-20 mA
3	RS232: TXD	15	OUTPUT No 5 <i>otherwise:</i> + ANALOG OUTPUT 0-10 VDC
4	RS232: RXD	16	OPZIONE E\EC <i>otherwise:</i> - ANALOG OUTPUT COMMON
5	OUTPUT No 1	17	RS485: -
6	OUTPUT No 2	18	RS485: +
7	OUTPUT No 3	19	- LOAD CELL EXCITATION (- Exc) LOAD CELL SHIELD
8	OUTPUT No 4	20	+ LOAD CELL EXCITATION (+ Exc)
9	OUTPUT COMMON	21	+ LOAD CELL REF / SENSE
10	INPUT No 1 (+VDC min 5V max 24V)	22	- LOAD CELL REF / SENSE
11	INPUT No 2 (+VDC min 5V max 24V)	23	- LOAD CELL SIGNAL (- Sig)
12	INPUT COMMON (-VDC 0V)	24	+ LOAD CELL SIGNAL (+ Sig)

BASIC INFORMATIONS

- It is recommended that the power supply negative pole be grounded.
- It is possible to supply up to eight 350 ohm load cells or sixteen 700 ohm load cells.
- For 4-wire load cells, make a jumper between EX- and REF- and between EX+ and REF+..
- Connect terminal “- SUPPLY” to the RS485 common of the connected instruments in the event that these receive alternating current input or that they have an optically isolated RS485.
- In case of an RS485 network with several devices it is recommended to activate the 120 ohm termination resistance on the two devices located at the ends of the network, as described in the paragraph **RS485 SERIAL CONNECTION**.
- Option **E\EC**: selects 12 groups of 5 setpoints.

WIRING DIAGRAM

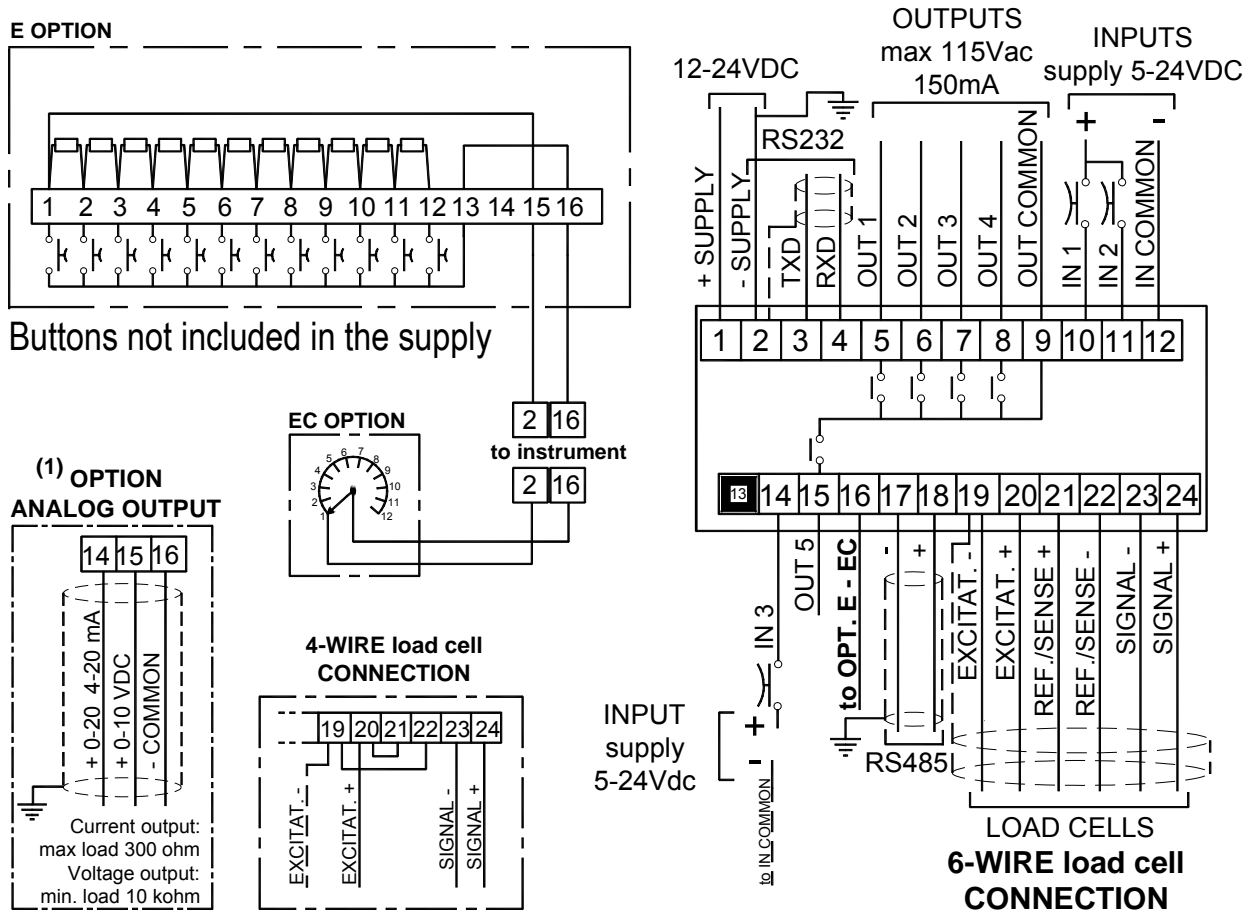

5 outputs: settable setpoints or remote output management via protocol.





3 inputs: settable to have the following functions: **NET/GROSS WEIGHT**, **SEMI-AUTOMATIC ZERO**, **PEAK**, **PRINT**, or **REMOTE CONTROL** (see paragraph **OUTPUTS AND INPUTS CONFIGURATION**).











(1) If the analog output is present (OPTION ANALOG OUTPUT) the following are no longer available:

- **IN3** input
- **OUT5** output
- **E / EC** options

LED AND KEY FUNCTIONS

LED	Main function	Secondary function *
NET	net weight LED: net weight display (semi-automatic tare or preset tare)	LED lit: input 1 closed
→0←	zero LED (deviation from zero not more than +/- 0.25 divisions)	LED lit: input 2 closed
	stability LED	LED lit: input 3 closed
kg	unit of measure: kg	LED lit: output 4 closed
g	unit of measure: g	LED lit: output 5 closed
W1		LED lit: output 1 closed
W2		LED lit: output 2 closed
W3		LED lit: output 3 closed

*) To activate the secondary LED function, during weight display press and hold down the keys  and  at the same time (press  immediately followed by ).

KEY	Short press	Long press (3 sec)	Into menus
	Semi-automatic zero	Tare resetting	Cancel or return to previous menu
	Gross → Net	Net → Gross	Select figure to be modified or return to previous menu item
	Prints actual weight	mV load cell test	Modify selected figure or go to next menu item
	Setting setpoints and hysteresis		Confirm or enter in submenu
	Setting general parameters (press  immediately followed by )		
	Setting preset tare (press  immediately followed by )		



The LEDs light up in sequence to indicate that a setting and not a weight is being viewed.

MENU MAP

Within the menu, the changes are applied immediately after pressing the  button (no further confirmation).

SETPOINTS

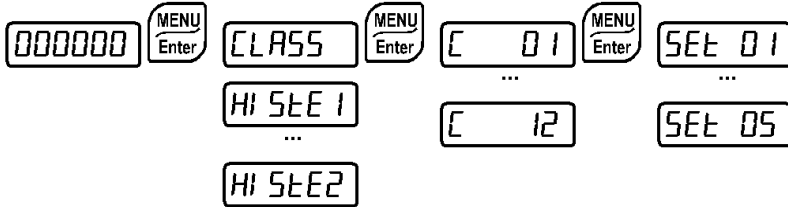

SYSTEM PARAMETERS

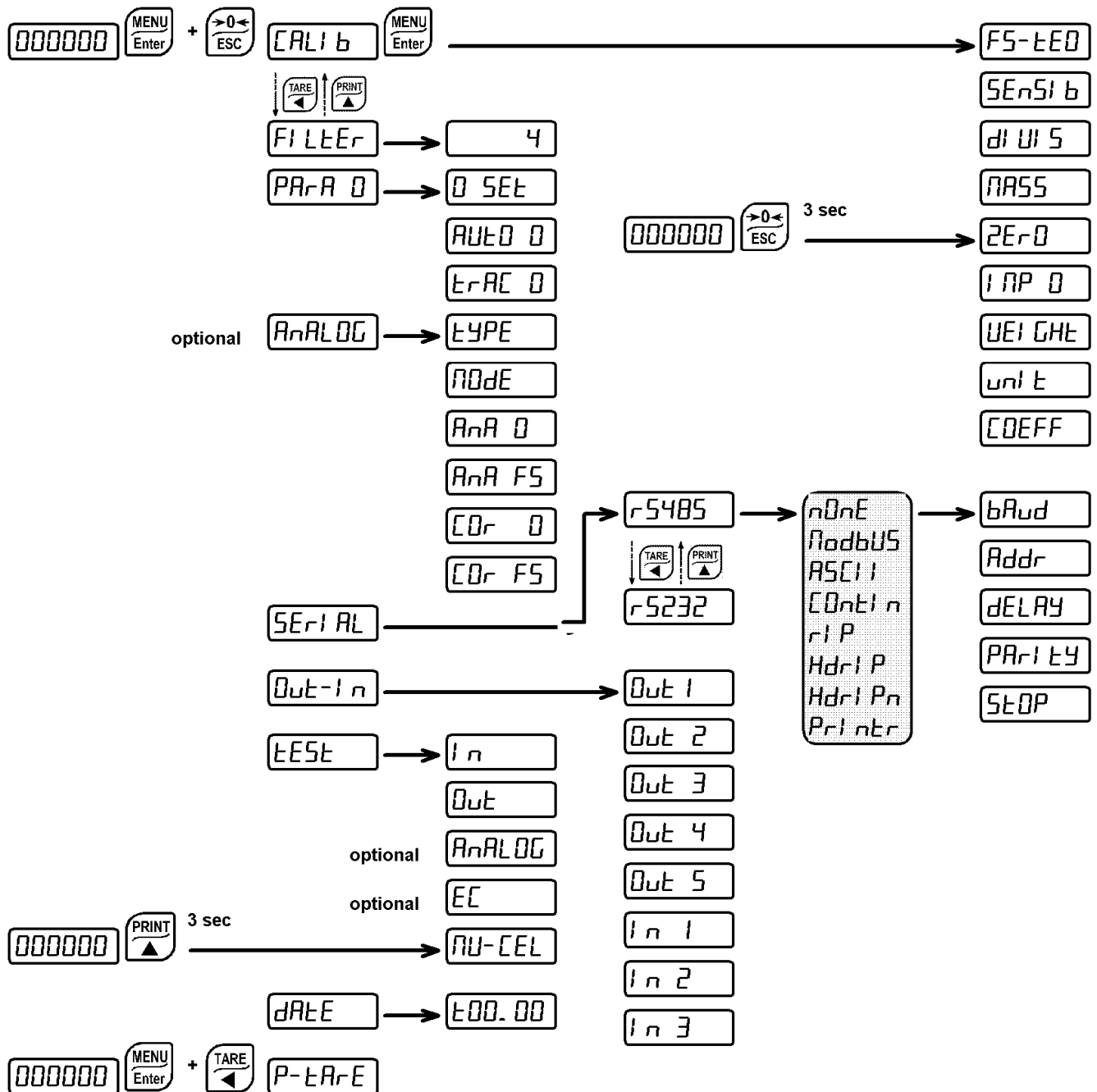

INSTRUMENT COMMISSIONING

Upon switch-on, the display shows in sequence:

- *111111* → *999999* (ONLY in case of approved program);
- instrument model (e.g.: *"U 100"*);
- *"SU"* followed by the software code (e.g.: *SU 5*);
- program type: *bASE* (base);
- *"r"* followed by the software version (e.g.: *r 1.04.01*);
- *"HU"* followed by the hardware code (e.g.: *HU 104*);
- the serial number (e.g.: *1005 15*);

Check that the display shows the weight and that when loading the load cells there is an increase in weight. If there is not check and verify the connections and correct positioning of the load cells.

- **If the instrument has already been theoretical CALIBRATED** (plant system identification tag present on the instrument and on the cover: load cell's rated data already entered):
 - Reset to zero (see paragraph **TARE WEIGHT ZERO SETTING**)
 - Check the calibration with sample weights and correct the indicated weight if necessary (see paragraph **REAL CALIBRATION (WITH SAMPLE WEIGHTS)**).
- **If the instrument HAS NOT BEEN CALIBRATED** (missing plant system identification tag) proceed with calibration:
 - If load cells data are unknown, follow the procedure in paragraph **REAL CALIBRATION (WITH SAMPLE WEIGHTS)**
 - Enter the rated data of load cells following the procedure given in paragraph **THEORETICAL CALIBRATION**
 - Reset to zero (see paragraph **TARE WEIGHT ZERO SETTING**)
 - Check the calibration with sample weights and correct the indicated weight if necessary (see paragraph **REAL CALIBRATION (WITH SAMPLE WEIGHTS)**).
- If you use the analog output, set the desired analog output type and the full scale value (see paragraph **ANALOG OUTPUT**).
- If you use serial communication, set the related parameters (see paragraph **SERIAL COMMUNICATION SETTING**).
- If setpoints are used, set the required weight values and the relevant parameters (see paragraphs **SETPOINTS PROGRAMMING** and **OUTPUTS AND INPUTS CONFIGURATION**).
- Set instrument's clock with current date and time (see paragraph **DATE AND TIME SETTING**)

PROGRAMMING OF SYSTEM PARAMETERS

From the weight display, press simultaneously keys  and  to access the parameter setting.

: to enter a menu or confirm the data entry.

: to modify the displayed value or menu item.

: to select a new value or modify the displayed menu item.

: to cancel and return to the previous menu.

THEORETICAL CALIBRATION

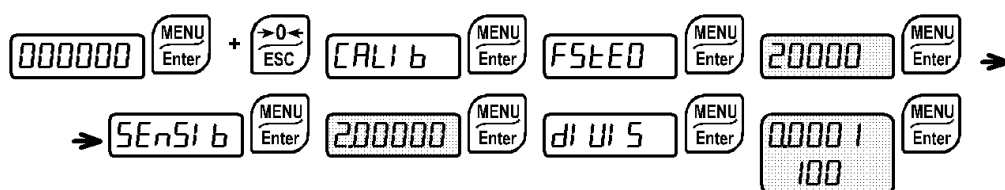

This function allows the load cell rated values to be set.

To perform the theoretical calibration set the following parameters in sequence:

- **FS-tE0** (Default: **dEΠ0**): The **system full scale** is given by one cell capacity multiplied by the number of cells used. Example of system full scale value calculation: 4 cells of 1000kg → FULL SCALE = 1000 X 4 = 4000. The instrument is supplied with a theoretical full scale value **dEΠ0** corresponding to 10000. To restore factory values, set 0 as full scale.
- **SEnSi b** (Default: 2.00000 mV/V): **Sensitivity** is a load cell rated parameter expressed in mV/V. Set the average sensitivity value indicated on the load cells. It's possible to set a value between 0.50000 and 7.00000 mV/V. Example of 4-cell system with sensitivity: 2.00100, 2.00150, 2.00200, 2.00250; enter 2.00175, calculated as $(2.00100 + 2.00150 + 2.00200 + 2.00250) / 4$.
- **di UI 5**: The **division** (resolution) is the minimum weight increment value which can be displayed. It is automatically calculated by the system according to the performed calibration, so that it is equal to 1/10000 of full scale. It can be changed and be variable between 0.0001 and 100 with x1 x2 x5 x10 increments.



- By modifying the theoretical full scale, the sensitivity or divisions, the real calibration is cancelled and the theoretical calibration only is considered valid.
- If the theoretical full scale and the recalculated full scale in real calibration (see paragraph **REAL CALIBRATION (WITH SAMPLE WEIGHTS)**) are equal, this means that the calibration currently in use is theoretical; if they are different, the calibration in use is the real calibration based on sample weights.
- By modifying the theoretical full scale, the sensitivity or divisions and all the system's parameters containing a weight value will be set to default values (setpoints, hysteresis, etc.).

MAXIMUM CAPACITY

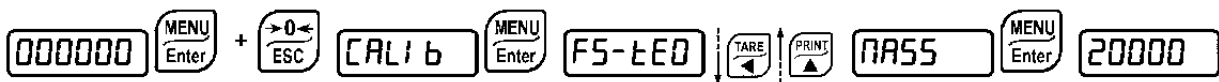

PASS: Maximum displayable weight (from 0 to max full scale; default: 0). When the weight exceeds this value by 9 divisions the following is displayed '-----'. To disable this function, set 0.

TARE WEIGHT ZERO SETTING

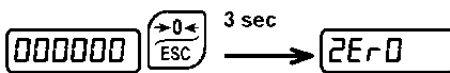
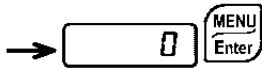



This menu may also be accessed directly from the weight display, holding down the  key for 3 seconds.

Perform this procedure after having set the THEORETICAL CALIBRATION data.

Use this function to set to zero the weight of the empty system after commissioning and then later on to compensate zero variations due to the presence of product residues.

Procedure:

- Confirm the message **ZEr0** (Zero) by pressing .
- The weight value to be set to zero is displayed. In this phase all of the LEDs are flashing.
- Confirming once again, the weight is set to zero (the value is stored to the permanent memory).
- Press  to display the value of the total weight reset by the instrument, given by the sum of all of the previous zero settings.

ZERO VALUE MANUAL ENTRY

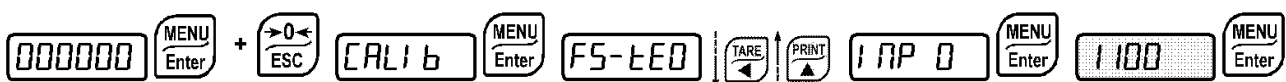

WARNING: Perform this procedure only if it's not possible to reset the weighed structure tare, for example because it contains product that can not be unloaded.

Set in this parameter the estimated zero value (from 0 to max 999999; default: 0).

REAL CALIBRATION (WITH SAMPLE WEIGHTS)

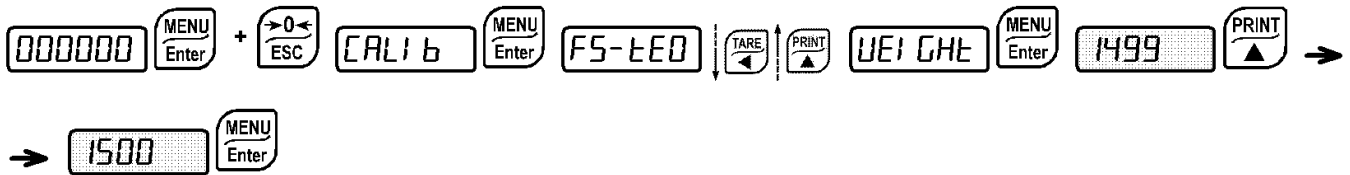

After having performed the **THEORETICAL CALIBRATION** and **TARE WEIGHT ZERO SETTING**, this function allows correct calibration to be done using sample weights of known value and, if necessary, any deviations of the indicated value from the correct value to be corrected.

Load onto the weighing system a sample weight, which must be **at least 50%** of the maximum quantity to be weighed.

By confirming the message **UEI GHE** the flashing value of the weight currently on the system is displayed. In this phase all of the LEDs are off. Adjust the value on display by using the arrow keys if necessary. After confirming, the new set weight will appear with all the LEDs flashing.

After an additional confirmation, the message **UEI GHE** will be restored and by repeatedly pressing the key  the weight will once again be displayed.

Example: for a system of maximum capacity 1000 kg and 1 kg division, two sample weights are available, one of 500 kg and the other one of 300 kg. Load both weights onto the system and correct the indicated weight to 800. Now remove the 300 kg weight, the system must show 500; remove the 500 kg weight, too; the system must read zero. If this does not happen, it means that there is a mechanical problem affecting the system linearity.

CAUTION: identify and correct any mechanical problems before repeating the procedure.



- If theoretical full scale and recalculated full scale in real calibration are equal, it means that the theoretical calibration is currently in use; otherwise, the real calibration based on sample weights is in use.
- If the correction made changes the previous full scale for more than 20%, all the parameters with settable weight values are reset to default values.

LINEARISATION OPTION ON MAX 5 POINTS:

It is possible to perform a linearisation of the weight repeating the above-described procedure up to a maximum of five points, using five different sample weights. The procedure ends by

pressing the  button or after entering the fifth value; at this point it will no longer be possible to change the calibration value, but only to perform a new real calibration. To perform a new calibration, should return to the weight display and then re-entering into the calibration menu.

By pressing  after having confirmed the sample weight that has been set, the full scale appears, recalculated according to the value of the maximum sample weight entered and making reference to the cell sensitivity set in the theoretical calibration (**SEN5! b**).

FILTER ON THE WEIGHT



Setting this parameter allows a stable weight display to be obtained.

To increase the effect (weight more stable) increase the value (from 0 to 9, default 4).

As seen in the diagram:

- By confirming the *FILTER* message, the currently programmed filter value is displayed.
- By changing and confirming the value, the weight is displayed and it will be possible to experimentally verify its stability.
- If stability is not satisfactory, confirming brings back the message *FILTER* and the filter may be modified again until an optimum result is achieved.

The filter enables to stabilise a weight as long as its variations are smaller than the corresponding "Response Time". It is necessary to set this filter according to the type of application and to the full scale value set.

FILTER VALUE	Response times [ms]	Display and serial port refresh frequency [Hz]
0	12	300
1	150	100
2	260	50
3	425	25
4 (default)	850	12.5
5	1700	12.5
6	2500	12.5
7	4000	10
8	6000	10
9	7000	5

ZERO PARAMETERS

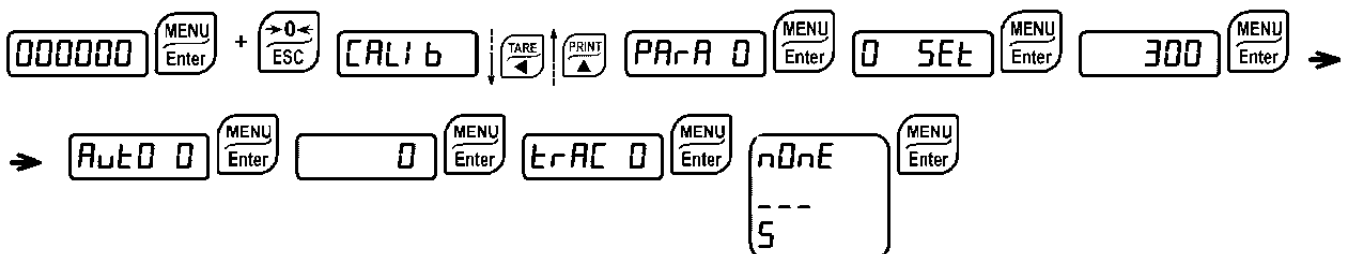

RESETTABLE WEIGHT SETTING FOR SMALL WEIGHT CHANGES

0 SET (from 0 to max full scale; default: 300; considered decimals: 300 – 30.0 – 3.00 – 0.300): this parameter indicates the maximum weight value resettable by external contact, keypad or serial protocol.

AUTOMATIC ZERO SETTING AT POWER-ON

AUTO 0 (from 0 to max 20% of full scale; default: 0): If at switch-on the weight value is lower than the value set in this parameter and does not exceed the **SET** value, the weight is reset. To disable this function, set 0.

ZERO TRACKING

TRAC 0 (from 1 to 5, default: **none**): When the zero weight value is stable and, after a second, it deviates from zero by a figure in divisions smaller or equal to the figure in divisions set in this parameter, the weight is set to zero. To disable this function, set **none**.

Example: if the parameter **dl UI 5** is set to 5 and **TRAC 0** is set to 2, the weight will be automatically set to zero for variations smaller than or equal to 10 (**dl UI 5** x **TRAC 0**).

SETTING UNITS OF MEASURE



Available unit of measure are:

HI LOG: kilograms

G: grams

t: tons

Lb: pounds*

nEUton: newton*

LI tRE: litres*

bAr: bar*

AtP: atmospheres*

PI ECE: pieces*

nEU-P: newton metres*

HI LO-P: kilogram metres*

0tHEr: other generic units of measure not included in the list*

If the print function is enabled, the symbol corresponding to the selected unit of measure will be printed after the measured value.



For the units marked with * it's possible to set also the display coefficient (parameter **COEFF**, see the related paragraph). To use **COEFF** is necessary to enable it, closing the **COEFF** input (see paragraph **OUTPUTS AND INPUTS CONFIGURATION**).

DISPLAY COEFFICIENT

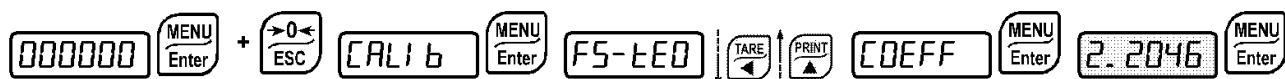

By setting the coefficient **COEFF** the display is changed accordingly.

If one of the inputs is set to **Coeff** mode (see paragraph **OUTPUTS AND INPUTS CONFIGURATION**) when the input is closed the value will be displayed modified according to the **Coeff** coefficient; when the input is opened the standard weight display will be restored.

Coeff: (max settable value: 99.9999; default: 1.0000) will have different meanings according to the value set in **Unit**, i.e. the selected unit of measure. (see paragraph **SETTING UNITS OF MEASURE**).

If the unit of measure chosen is:

Lb: pounds, the value set in **Coeff** will be multiplied by the weight value currently displayed;

Newton: newton, the value set in **Coeff** will be multiplied by the weight value currently displayed;

Litre: litres, in **Coeff** set the specific weight in kg/l, assuming that the system is calibrated in kg;

Bar: bar, the value set in **Coeff** will be multiplied by the weight value currently displayed;

Atm: atmosphere, the value set in **Coeff** will be multiplied by the weight value currently displayed;

Piece: pieces, in **Coeff** set the weight of one piece;

Newton-m: newton metres, the value set in **Coeff** will be multiplied by the weight value currently displayed;

kg-m: kilogram metres, the value set in **Coeff** will be multiplied by the weight value currently displayed;

Other: generic unit of measure not included in the list, the value set in **Coeff** will be multiplied by the weight value currently displayed.



CAUTION: All other settings (setpoints, hysteresis, calibration ...) are expressed in weight value. If you want to convert them to the new unit of measurement, perform one of the following procedures for changing the system calibration.

The parameter **Coeff** must remain set to 1.0000.

THEORETICAL CALIBRATION'S CHANGE FOR OTHER UNITS OF MEASURE

Set in the parameter **F5-EE** the F.SCALE value divided by the conversion coefficient from kg to the new unit of measure.

Example: The 4 load cells of 1000 kg are placed under a scale for olive oil, which has a specific gravity of 0,916 kg / l. Setting the F.SCALE = $(4 \times 1000) / 0,916 = 4367$, the system works in liters of olive oil. Also, if you set the parameter **Unit = Litre** (see paragraph **SETTING UNITS OF MEASURE**), the system will display and print the symbol 'l' instead of 'kg'.

REAL CALIBRATION'S CHANGE FOR OTHER UNITS OF MEASURE

Load a known quantity of product litres on the scale (equal to at least 50% of the maximum amount that you must weigh) and enter in the parameter **UEI CH**, the product loaded value in litres. Also, if you set the parameter **Unit = Litre** (see paragraph **SETTING UNITS OF MEASURE**), the system will display and print the symbol 'l' instead of 'kg'.

OUTPUTS AND INPUTS CONFIGURATION

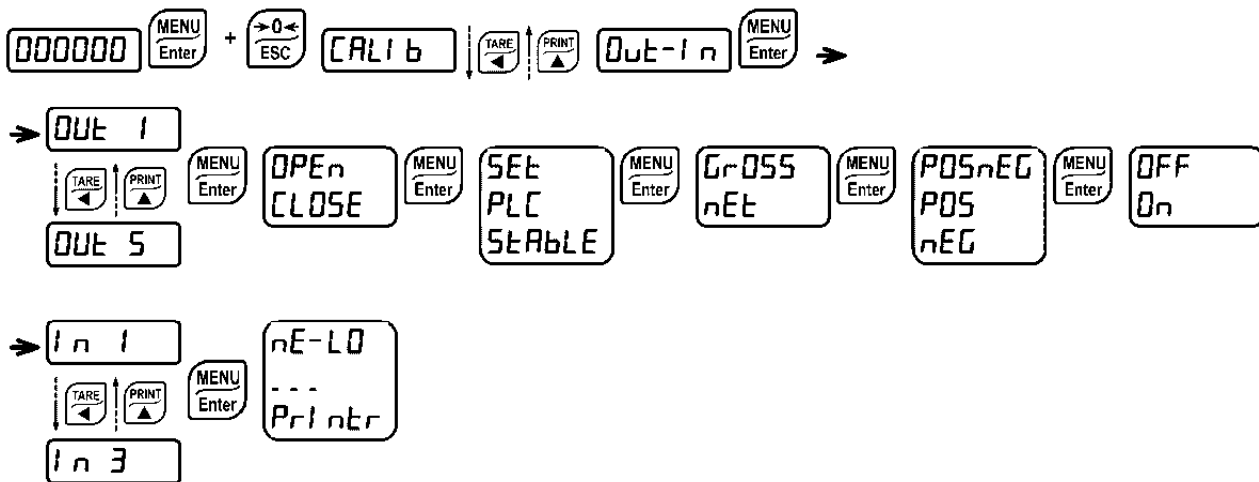

OUTPUTS

The outputs are set by default as follows: *OPEN* / *SET* / *POSnEG* / *OFF*.

Possible operation modes:

- **OPEN (normally open):** the relay is de-energised and the contact is open when the weight is lower than the programmed setpoint value; it closes when the weight is higher than or equal to the programmed setpoint value.
- **CLOSE (normally closed):** the relay is energised and the contact is closed when the weight is lower than the programmed setpoint value; it opens when the weight is higher than or equal to the programmed setpoint value.
- **SET:** the contact will switch on the basis of weight, according to setpoints (see paragraph **SETPOINTS PROGRAMMING**).
- **PLC:** the contact will not switch on the basis of weight, but is controlled by remote protocol commands.
- **STABLE:** relay switching occurs when the weight is stable.
- If the operation mode **SET** is selected, the following options are also active:
 - **GROSS:** the contact will switch on the basis of gross weight.
 - **nEt:** the contact will switch on the basis of net weight (If the net function is not active, the contact will switch on the basis of gross weight).
 - **POSnEG:** relay switching occurs for both positive and negative weight values.
 - **POS:** relay switching occurs for positive weight values only.
 - **nEG:** relay switching occurs for negative weight values only.

By confirming with  the setpoints operation can be set to the value '0':

- **OFF:** relay switching will not occur if the setpoint value is '0'.
- **On:**
 - Setpoint = '0' and *NOdES=POSnEG*, relay switching occurs when the weight is '0'; the relay will switch again when the weight is different from zero, taking hysteresis into account (both for positive and for negative weights).
 - Setpoint = '0' and *NOdES=POS*, relay switching occurs for a weight higher than or equal to '0', the relay will switch again for values below '0', taking hysteresis into account.

- Setpoint = '0' and $NODES=NEG$, relay switching occurs for a weight lower than or equal to '0', the relay will switch again for values above '0', taking hysteresis into account.

INPUTS

Default: input 1 = $ZERO$ input 2 = $NET-GROSS$ input 3 = $PEAK$

Possible operation modes:

- $NET-GROSS$ (NET/GROSS): by closing this input for no more than one second, it's making an operation of SEMI-AUTOMATIC TARE and the display will show the net weight. To display the gross weight again, hold the NET/GROSS input closed for 3 seconds.
- $ZERO$: by closing the input for no more than one second, the weight is set to zero (see paragraph **WEIGHT ZERO-SETTING FOR SMALL VARIATIONS (SEMI-AUTOMATIC ZERO)**).
- $PEAK$: keeping the input closed the maximum weight value reached remains on display. Opening the input the current weight is displayed.
- PLC : closing the input no operation is performed, the input status may however be read remotely by way of the communication protocol.
- $CONTIN$: closing the input for max one second the weight is transmitted over the serial connection according to the fast continuous transmission protocol only once (**only if $CONTIN$ is set in the item SERIAL**).
- $COEFF$: when the input is closed the weight is displayed based on the set coefficient (see setting of the units of measure and coefficient), otherwise the weight is displayed.
- $PRINT$: when the input is closed the data are sent for printing if in the communication protocol of either serial port the parameter $PRINT$ is set.

SEMI-AUTOMATIC TARE (NET/GROSS)



THE SEMI-AUTOMATIC TARE OPERATION IS LOST UPON INSTRUMENT POWER-OFF.

To perform a net operation (SEMI-AUTOMATIC TARE), close the NET/GROSS input or press the  key for less than 3 seconds. The instrument displays the net weight (just set to zero) and the NET LED lights up.

To display the gross weight again, keep the NET/GROSS input closed or press  for 3 seconds. This operation can be repeated many times by the operator to allow the loading of several products.

Example of weighing fruit in a box:

Put the box on the scale, the display shows the box weight, press  and the display shows the net weight to zero; by introducing the fruit in the box, the display shows the fruit weight. This operation can be repeated several times.



During the net weight displaying, keep pressed the  key to temporarily display the gross weight. As soon as the key is released, the net weight will be displayed again.

The semi-automatic tare operation is not allowed if the gross weight is zero.

PRESET TARE (SUBTRACTIVE TARE DEVICE)



It is possible to manually set a preset tare value to be subtracted from the display value provided that the $P-TARE \leq \text{max capacity}$ condition is verified.

After setting the tare value, going back to the weight display, the display shows the net weight (subtracting the preset tare value) and the NET LED lights up to show that a tare has been entered.

To delete a preset tare and return to gross weight display, hold down  for about 3 seconds or keep the NET/GROSS input (if any) closed for the same length of time (3 seconds). The preset tare value is set to zero. The NET LED is turned off when the gross weight is displayed once again.



During the net weight displaying, keep pressed the  key to temporarily display the gross weight. As soon as the key is released, the net weight will be displayed again.





- IF A SEMI-AUTOMATIC TARE (NET) IS ENTERED, IT IS NOT POSSIBLE TO ACCESS THE ENTER PRESET TARE FUNCTION.
- IF A PRESET TARE IS ENTERED, IT'S STILL POSSIBLE TO ACCESS THE SEMI-AUTOMATIC TARE (NET) FUNCTION. THE TWO DIFFERENT TYPES OF TARE ARE ADDED.



ALL THE SEMI-AUTOMATIC TARE (NET) AND PRESET TARE FUNCTIONS WILL BE LOST WHEN THE INSTRUMENT IS TURNED OFF.

SEMI-AUTOMATIC ZERO (WEIGHT ZERO-SETTING FOR SMALL VARIATIONS)

By closing the SEMI-AUTOMATIC ZERO input, the weight is set to zero; alternatively, by pressing the  key for less than 3 seconds, the $SEZEP$ message is displayed for 3 seconds, by pressing  the weight is set to zero.

This function is only allowed if the weight is lower than the $0 SEZ$ value (see paragraph **RESETTABLE WEIGHT SETTING FOR SMALL WEIGHT CHANGES**), otherwise the alarm $E-----$ appears and the weight is not set to zero.

PEAK

Keeping the input closed the maximum weight value reached remains displayed. Opening the input the current weight is displayed.



If you wish to use this input to view a sudden variation peak, set the FILTER ON THE WEIGHT to 0.

ANALOG OUTPUT (ONLY FOR INSTRUMENTS WHERE THIS OPTION IS AVAILABLE)

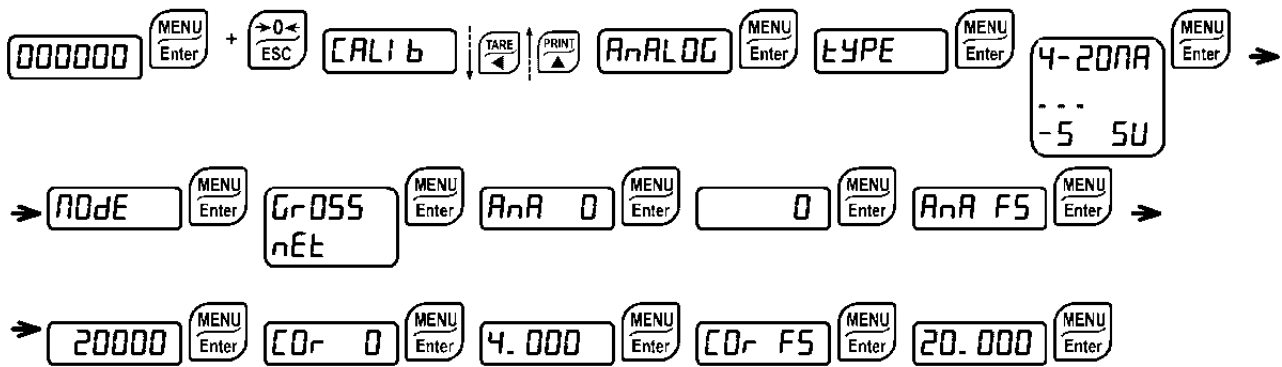

- **tYPE**: it selects the analog output type (4-20 mA, 0-20 mA, 0-10 V, 0-5 V, -10 +10 V, -5 +5 V; default: 4-20mA).



For the output -10 +10 V and -5 +5 V the soldered jumper SW1 must be closed:

- open the instrument, releasing with a screwdriver the locking tabs that hold together the two sides of the case;
- locate in the printed circuit board the soldered jumper SW1 highlighted in the picture below:

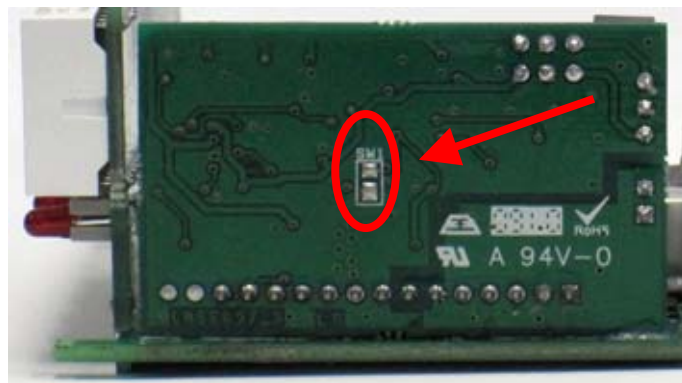

- close the jumper shorting the pads with a drop of tin.

- **NOdE**: choice of a weight followed by the analog output: gross (**GrOSS**) or net (**nEt**). If the net function is not active, the analog output varies according to gross weight.
- **AnA 0**: set the weight value for which you wish to obtain the minimum analog output value.



Only set a value different from zero if you wish to limit the analog output range; for instance: for a full scale value of 10000 kg you require an 4 mA signal at 5000 kg and 20 mA at 10000 kg, in this case, instead of zero, set 5000 kg.

- **AnA FS**: set the weight value for which you wish to obtain the maximum analog output value; it must correspond to the value set in the PLC program (default: calibration full scale). E.g.: if I am using a 4-20 mA output and in the PLC program I wish to have 20 mA = 8000 kg, I will set the parameter to 8000.
- **COr 0**: analog output correction to zero: if necessary adjust the analog output, allowing the PLC to indicate 0. The sign '-' can be set for the last digit on the left. E.g.: if I use a 4-20 mA output and, with the minimum analog setting, the PLC or tester read 4.1 mA, I must set the parameter to 3.9 to obtain 4.0 on the PLC or tester.

- **AO- FS**: full scale analog output correction: if necessary adjust the analog output, allowing the PLC to indicate the value set in the **AO FS** parameter. E.g. if I use a 4-20 mA output with the analog set to full scale and the PLC or tester reads 19.9 mA, I must set the parameter to 20.1 to obtain 20.0 on the PLC or tester.

Minimum and maximum values which can be set for the zero and full scale corrections:

ANALOG OUTPUT TYPE	Minimum	Maximum
0-10 V	-0.150	10.200
0-5 V	-0.150	5.500
-10 +10 V	-10.300	10.200
-5 +5 V	-5.500	5.500
0-20 mA	-0.200	22.000
4-20 mA	-0.200	22.000

NOTE: the analog output may also be used in the opposite manner, i.e. the weight setting that corresponds to the analog zero (**AO 0**) may be greater than the weight set for the analog full scale (**AO FS**). The analog output will increase towards full scale as the weight decreases; the analog output will decrease as the weight increases.

E.g.:

AO 0 = 10000 AO FS = 0 analog output 0-10 V

Weight = 0 kg analog output = 10 V

Weight = 5000 kg analog output = 5 V

Weight = 10000 kg analog output = 0 V

SERIAL COMMUNICATION SETTINGS

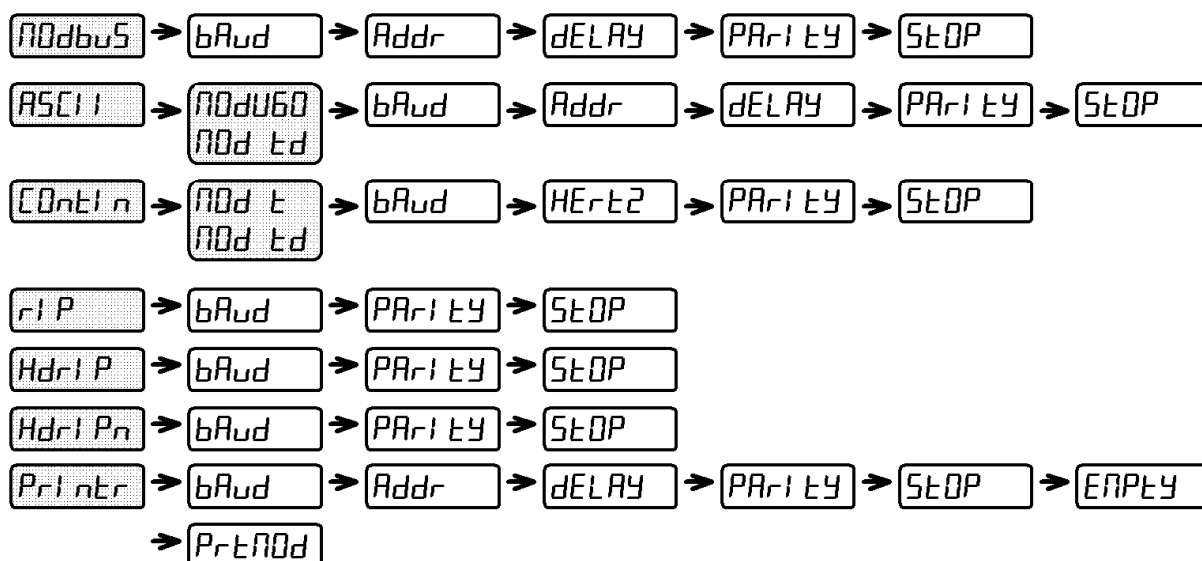

According to the chosen protocol only the necessary settings will be displayed in sequence (see diagram here above).

- *r5485* and *r5232*: communication port.
- *nOnE*: it disables any type of communication (default).
- *MOdbUS*: MODBUS-RTU protocol; possible addresses: from 1 to 99 (see Communication protocols manual).
- *ASCI I* : ASCII bidirectional protocol; possible addresses: from 1 to 99 (see Communication protocols manual).
 - *nOdU60*
 - *nOd t d*
- *COnti n*: continuous weight transmission protocol (see Communication protocols manual), at the frequency set in *HEr t2* item (from 10 to 300).
 - *nOd t* (set: *PARi tY*=*nOnE*, *StOP*= 1).
 - *nOd t d* (set: *PARi tY*=*nOnE*, *StOP*= 1).
- *rI P*: continuous weight transmission protocol to RIP5/20/60, RIP50SHA, RIPLD series remote displays; the remote display shows the net weight or gross weight according to its settings (set: *bAUd*=9600, *PARi tY*=*nOnE*, *StOP*= 1).
- *Hdri P*: continuous weight transmission protocol to RIP675, RIP6125C series remote displays; the remote display shows the net weight or gross weight according to its settings (set: *bAUd*=9600, *PARi tY*=*nOnE*, *StOP*= 1).
- *Hdri Pn*: continuous weight transmission protocol to RIP675, RIP6125C series remote displays (set: *bAUd*=9600, *PARi tY*=*nOnE*, *StOP*= 1).
When the remote display is set to gross weight:
 - if the instrument displays the gross weight, the remote display shows the gross weight.

- if the instrument shows the net weight, the remote display shows the net weight alternated with the message *nEt*.
 - *Printer*: printer.
 - *baud*: transmission speed (2400, 4800, 9600, 19200, 38400, 115200; default: 9600).
 - *Addr*: instrument's address (from 1 to 99; default: 1).
 - *HErEz*: maximum transmission frequency (10 – 20 – 30 – 40 – 50 – 60 – 70 – 80 – 100 – 200 – 300; default: 10); to be set when the *[QnE]n* transmission protocol is selected.
- Maximum setting frequency (*HErEz*):
- 20Hz with minimum baud rate 2400 baud.
 - 40Hz with minimum baud rate 4800 baud.
 - 80Hz with minimum baud rate 9600 baud.
 - 100Hz with minimum baud rate 19200 baud.
 - 200Hz with minimum baud rate 38400 baud.
 - 300Hz with minimum baud rate 38400 baud.
- *dELAY*: delay in milliseconds which elapses before the instrument replies (from 0 to 200 msec; default: 0).
 - *PARi ty*:
 - *nOnE*: no parity (default).
 - *EUEn*: even parity.
 - *Odd*: odd parity.
 - *StOP*: stop bit (1 – 2; default: 1).
 - *ENPEy*: number of blank lines between one printout and the next.
 - *PrEPOd*: connected printer type:
 - *P 190*
 - *StAUP*



For more information about protocols and methods of communication, request the proper manual to technical assistance.

RS232 SERIAL COMMUNICATION

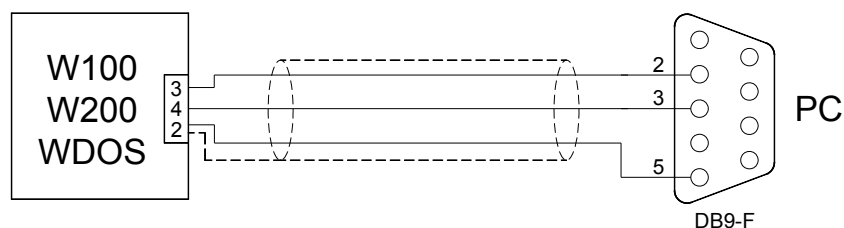

RS485 SERIAL COMMUNICATION

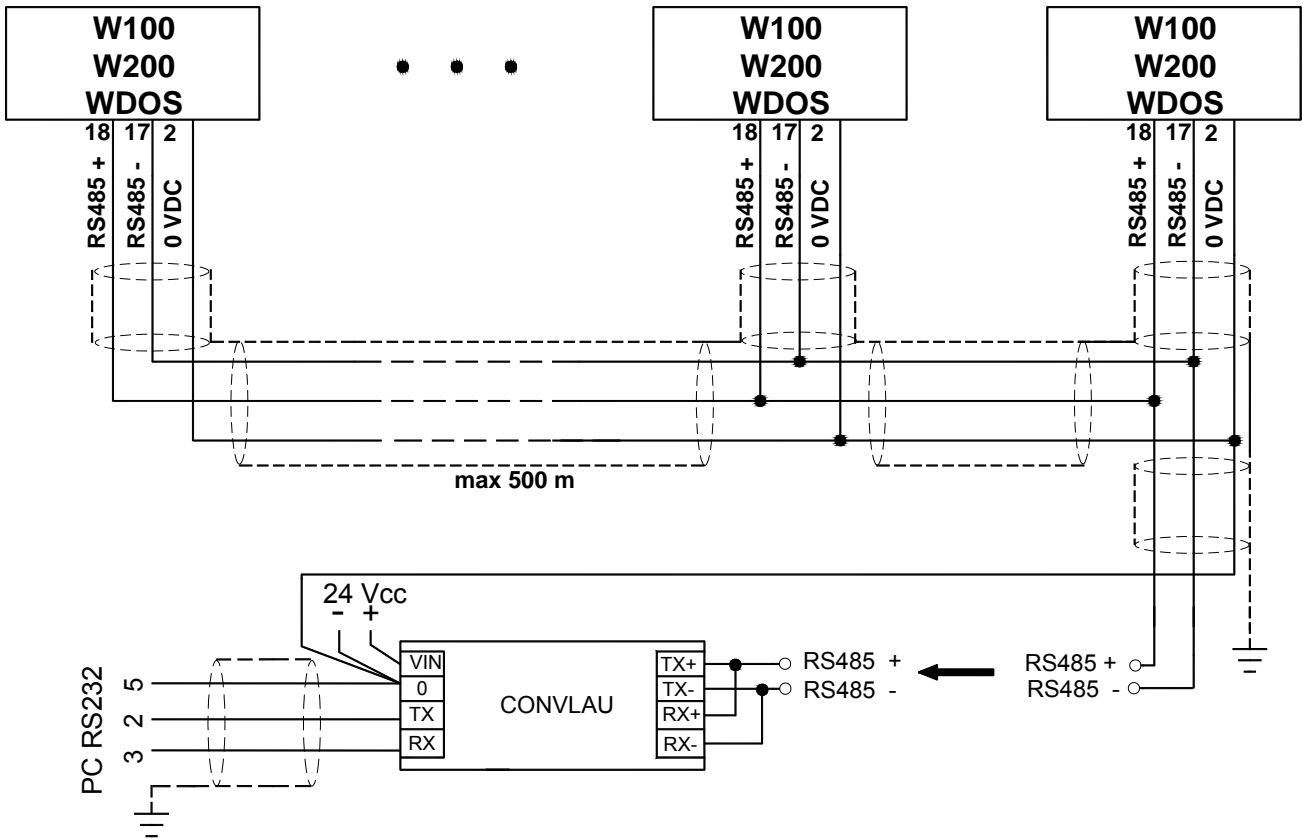

If the RS485 network exceeds 100 metres in length or baud-rate over 9600 are used, two terminating resistors are needed at the ends of the network. Two 120 ohm resistors must be connected between the '+' and '-' terminals of the line, on the terminal strip of the furthest instruments. Should there be different instruments or converters, refer to the specific manuals to determine whether it is necessary to connect the above-mentioned resistors.

DIRECT CONNECTION BETWEEN RS485 AND RS232 WITHOUT CONVERTER

Since a two-wire RS485 output may be used directly on the RS-232 input of a PC or remote display, it is possible to implement instrument connection to an RS-232 port in the following manner:

INSTRUMENT		RS232
RS 485 -	→	RXD
RS 485 +	→	GND



This type of connection allows A SINGLE instrument to be used in a ONE WAY mode.

TEST

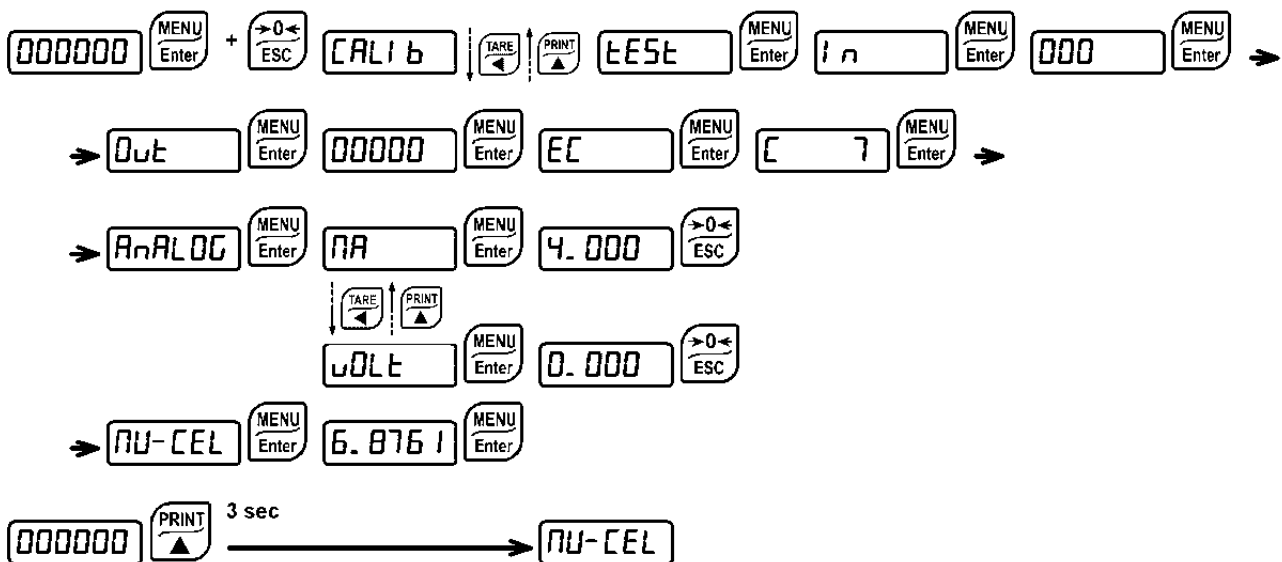

- **Input Test:**
In: ensure that for each open input *I* is displayed, *I* is displayed when the input is closed.
- **Output Test:**
Out: setting *I* ensure that the corresponding output opens. Setting *I* ensure that the corresponding output closes.
- **E/EC Option Test:**
EC: It shows the group number of setpoint selected by the E/EC option, if the option is not present or is not active, the message *EC-Err* is displayed.
- **Analog Output Option Test:**
AnALOG: It allows the analog signal to range between the minimum and the maximum values starting from the minimum.
NA: current output test.
vDLt: voltage output test.
- **Millivolt Test:**
NU-CEL: displays the load cell response signal in mV with four decimals.

DATE AND TIME SETTING



Selecting the *dAtE* item in the main menu, access is obtained to the date and time display menu.

Pressing several times scrolls through days - months – years and hours – minutes; pressing key selects the figure to modify; with key you can modify it; with key you can confirm and go to the next menu item.

SETPOINTS PROGRAMMING

From the weight display, press  to access the setpoints setting.

: to enter a menu or confirm the data entry.

: to modify the displayed value or menu item.

: to select a new value or modify the displayed menu item.

: to cancel and return to the previous menu.

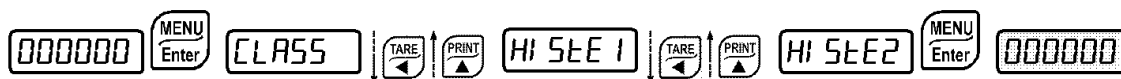
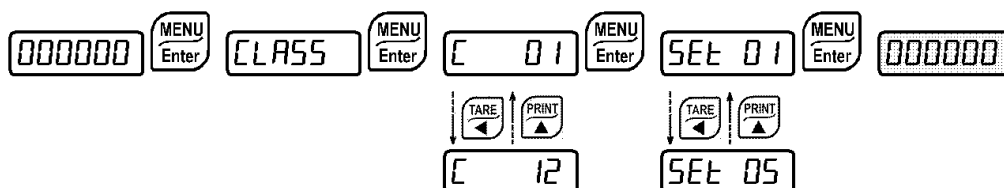

- **CLASS**: if the E/EC option is connected, it is possible to set 12 groups (classes) of different values for the setpoints; otherwise it is possible to set only the first class. Valid values for relays switching are selected by the EC/E position.
- **SEE** (from 0 to max full scale; default: 0): Setpoint; relay switching occurs when the weight exceed the value set in this parameter. The type of switching is settable (see paragraph **OUTPUTS AND INPUTS CONFIGURATION**).
- **HYSLE** (from 0 to max full scale; default: 0): Hysteresis, value to be subtracted from the setpoint to obtain contact switching for decreasing weight. For example with a setpoint at 100 and hysteresis at 10, the switching occurs at 90 for decreasing weight.



These values are set to zero if the calibration is changed significantly (see paragraphs **THEORETICAL CALIBRATION** and **REAL CALIBRATION (WITH SAMPLE WEIGHTS)**).

ALARMS

- Er CEL**: the load cell is not connected or is incorrectly connected; the load cell signal exceeds 39 mV; the conversion electronics (AD converter) is malfunctioning; the load cell is a 4-wire and there are no jumpers between EX- and REF- and between EX+ and REF+.
- Er DL**: the weight display exceeds 110% of the full scale.
- Er Ad**: internal instrument converter failure; check load cell connections, if necessary contact technical assistance.
- : the weight exceeds the maximum weight by 9 divisions.
- Er DF**: maximum displayable value exceeded (value higher than 999999 or lower than -999999).

E-----: weight too high: zero setting not possible.

PAH-PU: this message appears in the sample weight setting, in real calibration, after the fifth sample weight value has been entered.

Error: the value set for the parameter is beyond the permitted values; press  to quit the setting mode leaving the previous value unchanged. Examples: a number of decimals is selected for full scale which exceeds the instrument's display potential; value above the maximum setting value; the weight value set in sample weight verification does not match the detected mV increase; the analog output correction goes beyond the permitted limits.

LOCK: lock active on menu item, keypad or display.

n0d! SP: It's not possible to display properly the number because is greater than 999999 or less than -999999.

bAe-EE: buffer battery low, loss of date and time of Real-Time Clock. Confirm with  to continue; leave the instrument on for at least 12 hours to charge the battery, if the alarm persists contact technical assistance.

dAEEP: an incorrect date has been detected: go into the related menu to check and correct it.

Serial protocols alarms:

	<i>ErCEL</i>	<i>Er OL</i>	<i>Er Ad</i>	<i>-----</i>	<i>Er OF</i>	<i>E-----</i>
MODE						
Bit LSB	76543210	76543210	76543210	76543210	76543210	The response to the zero command is a 'value not valid' error (error code 3)
Status Register MODBUS RTU	xxxxxxxx1	xxxx1xxx	xxxxxxxx1x	xxxxx1xx	On gross: xxx1xxxx On net: xx1xxxxx	
ASCII	<u> </u> <i>O-F</i> <u> </u>	<u> </u> <i>O-L</i> <u> </u>	<u> </u> <i>O-F</i> <u> </u>	<u> </u> <i>O-L</i> <u> </u>	<u> </u> <i>O-F</i> <u> </u>	&aa#CR
RIP *	<u> </u> <i>O-F</i> <u> </u>	<u> </u> <i>O-L</i> <u> </u>	<u> </u> <i>O-F</i> <u> </u>	<u> </u> <i>O-L</i> <u> </u>	<u> </u> <i>O-F</i> <u> </u>	<u> </u> <i>O-F</i> <u> </u>
HDRIP-N	<u> </u> <i>ERCEL</i> <u> </u>	<u> </u> <i>ER_OL</i> <u> </u>	<u> </u> <i>ER_AD</i> <u> </u>	#####	<u> </u> <i>ER_OF</i> <u> </u>	<u> </u> <i>O_SET</i> <u> </u>
CONTIN	<u> </u> <i>ERCEL</i> <u> </u>	<u> </u> <i>ER_OL</i> <u> </u>	<u> </u> <i>ER_AD</i> <u> </u>	^^^^^^	<u> </u> <i>ER_OF</i> <u> </u>	<u> </u> <i>O_SET</i> <u> </u>

* For RIP remote displays, if the message exceeds 5 digits the display reads *-----*.

If an alarm becomes active the relays open and the analog outputs go to the lowest possible value according to the following table:

RANGE	0/20 mA	4/20 mA	0/5 V	0/10 V	-10/10 V	-5/5 V
Output value	-0.2 mA	3.5 mA	-0.5 V	-0.5 V	0 V	0 V

PRINTING EXAMPLES

If the printer has been set (see paragraph **SERIAL COMMUNICATION SETTINGS**), from the weight display press the  key for less than 3 seconds:

BASIC PRINTOUT

W100 BASE Addr:01
DATE: 12/09/11 14:48:12

GROSS	878 kg
NET	589 kg
TARE	289 kg

PRINTOUT WITH OPENED COEFFICIENT INPUT AND *COEFF* SET

W100 BASE Addr:01
DATE: 12/09/11 14:57:13

GROSS	1195 kg
NET	1195 kg
TARE	0 kg

PRINTOUT WITH CLOSED COEFFICIENT INPUT AND *COEFF* SET

In this printout both the values of the opened COEFFICIENT input (left column) and closed COEFFICIENT input are indicated.

W100 BASE Addr:01
DATE: 12/09/11 15:07:41

UNIT	kg	bar
G	1195	1792
N	1195	1792
T	0	0

PROGRAM SELECTION:

bASe: basic program, management of setpoints only.

rEUEr: to be used when the loaded weighing system correspond to not loaded cells and vice versa (product increases while weight on loading cells actually decreases).

r iP: remote display program with setpoints.

After confirming the choice of the program (except *rEUEr* and *r iP*), the user must choose the approval state of the program among the following possible choices:



nOtLEG: not approved program;

LEGAL: approved program, single division (Dir. 2009/23/EC, art. 1)*;

MULt-I: approved program, multi-interval (Dir. 2009/23/EC, art. 1)*;

MULt-r: approved program, multiple range (Dir. 2009/23/EC, art. 1)*;

- *) Contact technical assistance to request the proper manual and the correct procedures for approval, indicating mandatory hardware code and serial number (see paragraph **COMMISSIONING THE INSTRUMENT**).



By confirming the displayed program, the system variables are set with default values.

By pressing  you will quit the program without introducing any changes and without deleting any of the set variables.



If you do not have a specific manual for the newly set program, you can request it to technical assistance.

KEYPAD OR DISPLAY LOCKING

Press  immediately followed by  hold them down for about 5 seconds (this operation is also possible via the MODBUS and ASCII protocols):

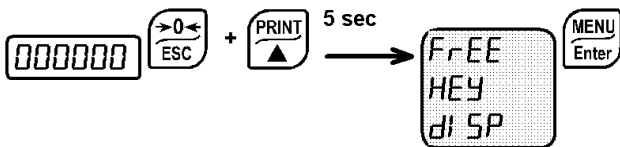

- *FrEE*: no lock.
- *HEy*: keypad lock: if active, when a key is pressed the message *bLOC* is displayed for 3 seconds.
- *dI SP*: keypad and display lock: if active, the keypad is locked and the display shows the instrument model (weight is not displayed); by pressing a key the display shows *bLOC* for 3 seconds.

DECLARATION OF CONFORMITY

LAUMAS[®]
ELETTRONICA

SISTEMI DI PESATURA INDUSTRIALE - CELLE DI CARICO



Sistema di gestione
Qualità certificato
UNI EN ISO 9001:2008



CERTIFICAZIONE DEL SISTEMA DI GARANZIA DELLA QUALITÀ DELLA PRODUZIONE

LAUMAS Elettronica S.r.l.
Tel. (+39) 0521 683124 - Fax (+39) 0521 681091
Via 1° Maggio 6 – 43022 Montechiarugolo (PR) Italy
C.F. - P.IVA IT01661140341

email: laumas@laumas.it

web: <http://www.laumas.com>





Fabbricante metrico Prot. N. 7340 Parma - R.E.A. PR N. 169833 - Reg. Imprese
PR N.19393 - Registro Nazionale Pile N° IT09060P00000982 - Registro A.E.E.
N° IT08020000002494 - N. Mecc. PR 008385 - Cap. Soc. Euro 10.400 int. vers.

EC-Konformitätserklärung
EC- Déclaration de conformité
EC-Dichiarazione di conformità
EC- Declaração de conformidade
EC-Deklaracja zgodności

EC-Declaration of Conformity
EC-Declaración de Conformidad
EC-Conformiteitverklaring
EC- Prohlášení o shode
EC-Заявление о соответствии

I	Dichiarazione di conformità	Dichiariamo che il prodotto al quale la presente dichiarazione si riferisce è conforme alle norme di seguito citate.
GB	Declaration of conformity	We hereby declare that the product to which this declaration refers conforms with the following standards.
E	Declaración de conformidad	Manifestamos en la presente que el producto al que se refiere esta declaración está de acuerdo con las siguientes normas
D	Konformitäts-erklärung	Wir erklären hiermit, dass das Produkt, auf das sich diese Erklärung bezieht, mit den nachstehenden Normen übereinstimmt.
F	Déclaration de conformité	Nous déclarons avec cela responsabilité que le produit, auquel se rapporte la présente déclaration, est conforme aux normes citées ci-après.
CZ	Prohlášení o shode	Tímto prohlašujeme, že výrobek, kterého se toto prohlášení týká, je v souladu s níže uvedenými normami.
NL	Conformiteit-verklaring	Wij verklaren hiermede dat het product, waarop deze verklaring betrekking heeft, met de hierna vermelde normen overeenstemt.
P	Declaração de conformidade	Declaramos por meio da presente que o produto no qual se refere esta declaração, corresponde às normas seguintes.
PL	Deklaracja zgodności	Niniejszym oświadczamy, że produkt, którego niniejsze oświadczenie dotyczy, jest zgodny z poniższymi normami.
RUS	Заявление о соответствии	Мы заявляем, что продукт, к которому относится данная декларация, соответствует перечисленным ниже нормам.

Models: W100

Mark Applied	EU Directive	Standards
	2006/95/EC Low Voltage Directive	<i>Not Applicable (N/A)</i> for VDC type EN 61010-1 for 230/115 VAC type
	2004/108/EC EMC Directive	EN 55022 EN 61000-6-2 EN 61000-6-4 EN 61000-4-2/3/4/5/6
  (only if "M" mark is applied)	2009/23/EC NAWI Directive	EN 45501:1992 OIML R76-1:2006

Montechiarugolo (PR), 13/03/2012

LAUMAS Elettronica s.r.l.
M. Consonni (**RCQ**)

