

# INSTRUCTION MANUAL

Conveyer/elevator type TG/TM 16

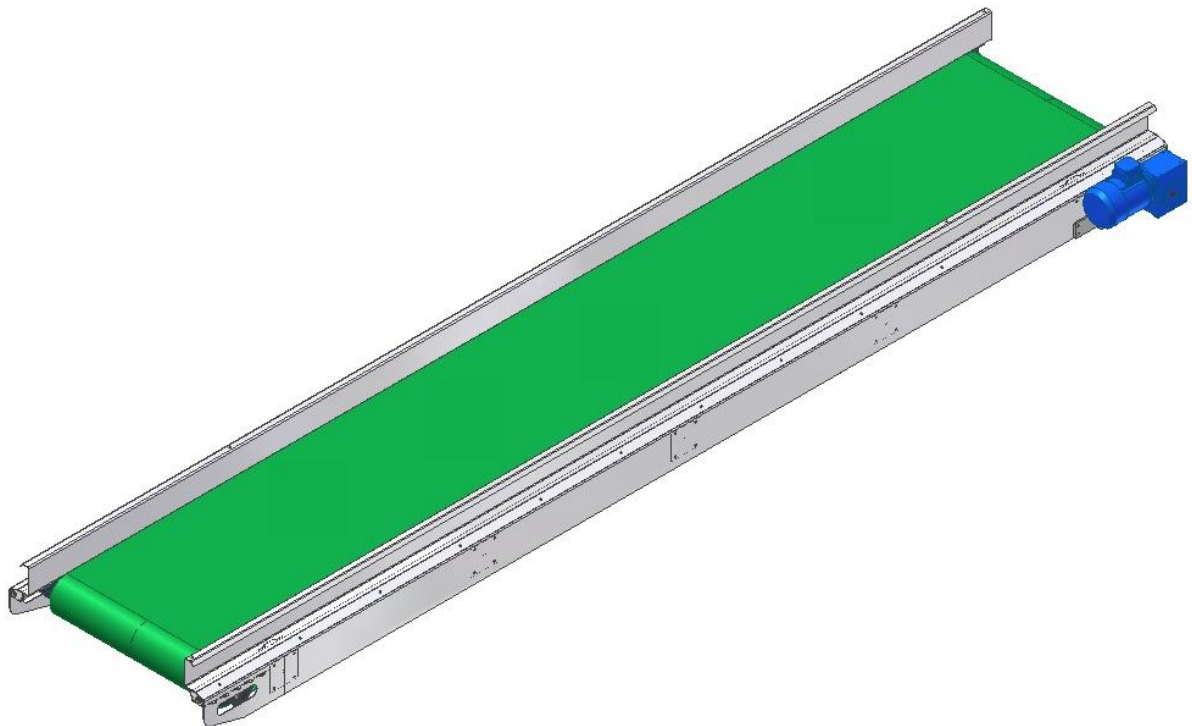

A/S SKALS MASKINFABRIK  
HOVEDGADEN 56  
DK-8832 SKALS, DANMARK  
Tlf.: +45 87 25 62 00  
Fax: +45 86 69 49 99  
E-mail: [Skals@skals.DK](mailto:Skals@skals.DK)  
<http://www.skals.DK/>



## **Contents**

Contents.....	1
1.0 Purpose and scope of operations .....	2
2.0 Installation.....	2
3.0 Operation.....	2
4.0 Pictograms.....	2
5.0 Lubrication and maintenance .....	2
5.1 Cleaning .....	3
6.0 Packing and transport information .....	4
7.0 Transport and lifting instructions .....	4
8.0 Spareparts .....	6
9.0 Declaration of conformity with EU.....	8

## 1.0 Purpose and scope of operations

The conveyor/ elevator is designed to be used for transport and dosing of potatoes, onions and similar products.

## 2.0 Installation

The conveyor/ elevator must stand firmly on all four legs on a level floor. Adjust the legs so that the machine stands level.

Connect the electricity supply in accordance with local regulations. Electricity supply should be connected through a motor protection relay, which corresponds to the size of the motor. If the conveyor/ elevator are supplied with a motor relay, connect the power supply to this.

## 3.0 Operation

When the conveyor/ elevator has been correctly placed in relation to other machines in the production sequence, start the machine by activating the motor relay.

If the conveyor/ elevator is supplied with a variable speed regulator, the speed regulator is regulated by turning the handle with the indicator on the variator. Ratio 5:1

Never turn the handle when the machine is not in operation.

## 4.0 Pictograms

Danger! Keep hands away from rollers. Keep a safe distance.

## 5.0 Lubrication and maintenance

All bearings and motors are lubricated for life and require no further maintenance. Grease nipples are mounted on the bearings as we by SKALS by the assembly make a refilling of bearings. This is done because of the low rotations speed of the bearings. The extra greasing improves the sealing in the bearing. If the bearings are refilled, this should be done with a minimum of 1000 hours interval or at the earliest for every 6 months. Make maximum 2 strokes with a standard grease gun on a TG / TM16. Too much lubrication can damage the seal and thereby shorten bearing life considerably.

The worm drive type NMRV is lubricated for life with IP TELIUM VSF, a synthetic grease suitable for a normal temperature range of -15°C to + 40°C.

	<b>Syntetisk</b>	<b>Mineralsk</b>
IP	Telium VSF	Mellena oil 220
Shell	Tivela oil SC320	Omala oil 220
Agib	Blasia S320	Blasia 220
Mobil	Glygoyle 30	Mobilgear 220
Castrol	Alphasyn PG 320	Alpha 220

Change oil after 5,000 production hours.

### **Variator**

The variator is mounted between the worm drive and the motor. It must always be kept filled with long life oil and should be topped up to the middle of the observation glass.

Change the oil every 8 years.

It is imperative that there is always the correct amount and type of oil in the variator.

Recommended oils:

IP	Transmission V. E.
IP	A.T.F. Dexron Fluid
AGIP	A.T.F. Dexron
BP	Autran DX
Chevron	A.T.F. Dexron
ESSO	A.T.F. Dexron
Fina	A.T.F. Dexron
Mobil	A.T.F. 220
Shell	A.T.F. Dexron
Castrol	TQ Dexron II.

Cylinders that are not driven directly by the motor are lubricated for life and require no maintenance.

In the case of a fault, the cylinder must be removed and returned to the factory for repair.

The conveyor must be kept taut and straight by adjusting the tension bolts on the conveyor.

## **5.1 Cleaning**

With reference to the Danish Plant Directorate's Order No. 965 of 13 December 1993 (p. 6).

- 2.3.3 Seed potato growers with contained propagation must clean and disinfect all sorting and ancillary equipment after each new variety. Disinfecting should be carried out using a product approved by The Danish Institute of Plant and Soil Science.
- 2.3.4 Companies authorised to sort potatoes and who also have the authorisation to propagate potatoes, must clean and disinfect sorting machinery etc. which is under the control of The Danish Plant Directorate before the sorting of own propagation is commenced. Disinfecting should be carried out using a product approved by The Danish Institute of Plant and Soil Science.
- 2.3.5 Premises and machinery etc. must be cleaned and disinfected each year before 30 June. Disinfecting must be carried out using a product approved by The Danish Institute of Plant and Soil Science.

In other countries, customers must conform to relevant, local food and hygiene regulations.

**When cleaning with high pressure equipment**, the following parts must be securely covered: Motor, variator, worm gear, conveyor cylinders, and all bearings.

In order to maintain effective production and keep maintenance costs at a minimum, regular lubrication, maintenance and cleaning are very important.

## 6.0 Packing and transport information

Number of units:

The machine is normally packed complete as one unit.

## 7.0 Transport and lifting instructions

Should it be necessary to lift the conveyor/ elevator, this must be carried out by using nylon straps or a chain sling fitted, as shown in the illustration below (fig. 1). The hook or the schackle had to mounted in the holes in the transport/lifting bracket. It is always important that the lifting points are fitted on the conveyor in a way that gives a good weight balance.

Please be attention to that the spread angle between the slings/chains maximal must be 120 degrees. This maximal angle have to be respected in all situations where there have to be lifted one or more conveyors. The maximal spread angle can be at the diagonal, at cross or at along the legs in a 4-legged sling. In figure 1, the maximal angle has been showed as the angle between the diagonal legs.

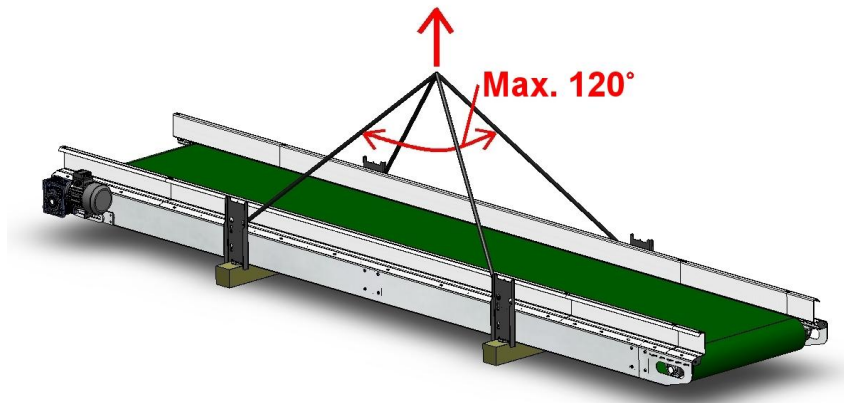

Figure 1

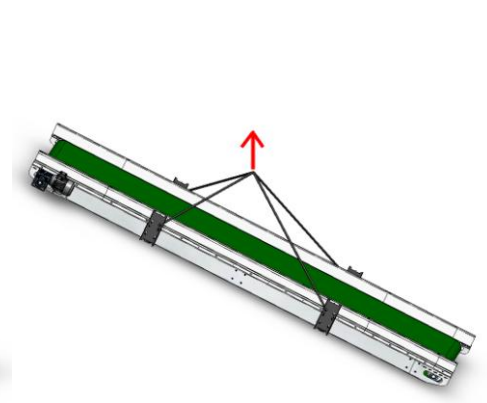

Figure 2

The same brackets can be used when mounting a conveyor, that have to placed in an angle (elevator). Like before the spread angle must maximal be 120 degrees. See figure 2.

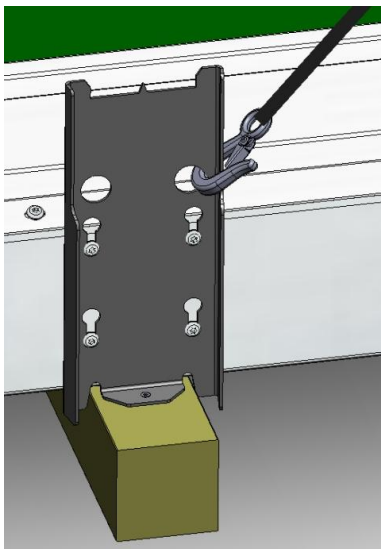

Figure 3

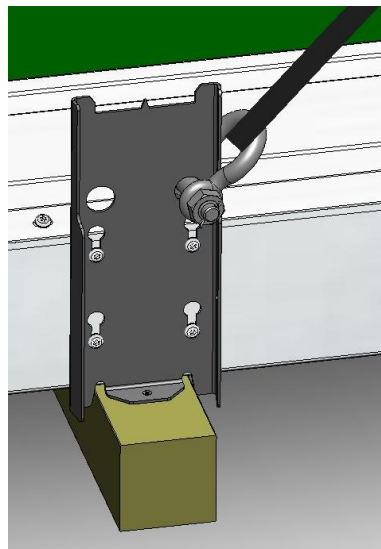

Figure 4

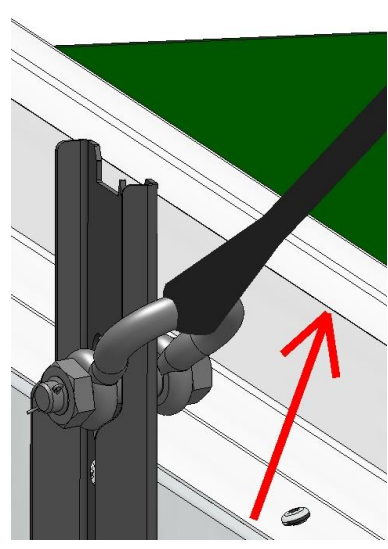

Figure 5

To attach a chain or a strap to the bracket, you have to use a safety hook (figure 3) or a schackle (figure 4). If you are not using a chain, but ex. a nylon strap, you have to observe that the strap not is lying on the sharp edge on the side plate (the edge is showed on the figure 5). If you can not avoid this, there have to be some kind of protecting between the strap and the side plate. Then we are avoiding that the strap can be cut over.

If there have to be sent more than one conveyor at a time, these will under normal circumstances be packed as one unit. To do this the bracket will be used. See figure 6. In the most cases it will be possible to lift the whole stack in the brackets that are mounted on the conveyor that is in the bottom.

Again you have to be aware of the sharp edge on the side plate and that the spread angle between the slings/chains maximal must be 120 degrees.

See figure 6 for an illustration of the lift.

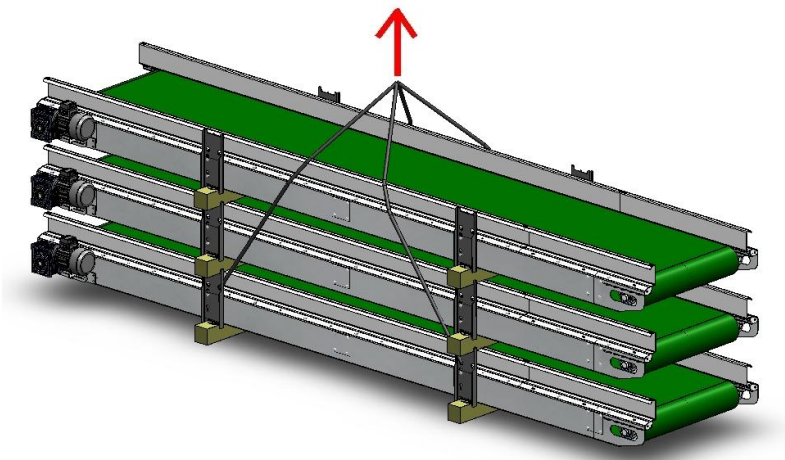

Figure 6

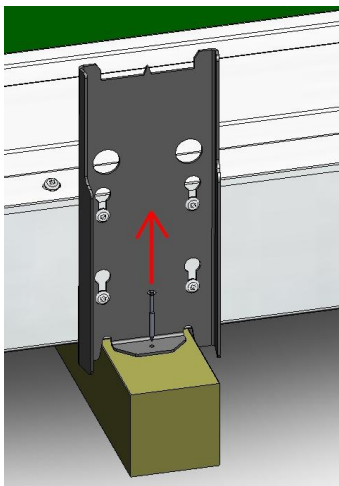

Figure 7

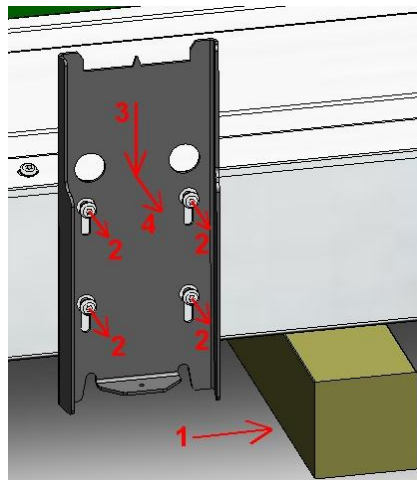

Figure 8

To dismantle the transport/lifting bracket, the screw on figure 7 must be screwed out. Then the bar, under the conveyor, must be moved to the side, see arrow nr.1 on the figure 8. Now the 4 pieces of M8 mm screws must be screwed half the way out, see arrow nr. 2 on figure 8. When they have been Untightened, the bracket can unmounted by just let I drop down and then take it out, see arrow nr. 3 and 4 on figure 8. At last the 4 pieces of M8 screws must be tighten again. They must be tighten as must as they were before, its about 8-10Nm. If the bracket must be moved or used again, you must follow this guide in conversely direction.

## 8.0 Spareparts

When ordering spares, state machine type, serial no. and, if possible, position no..

Figure 2

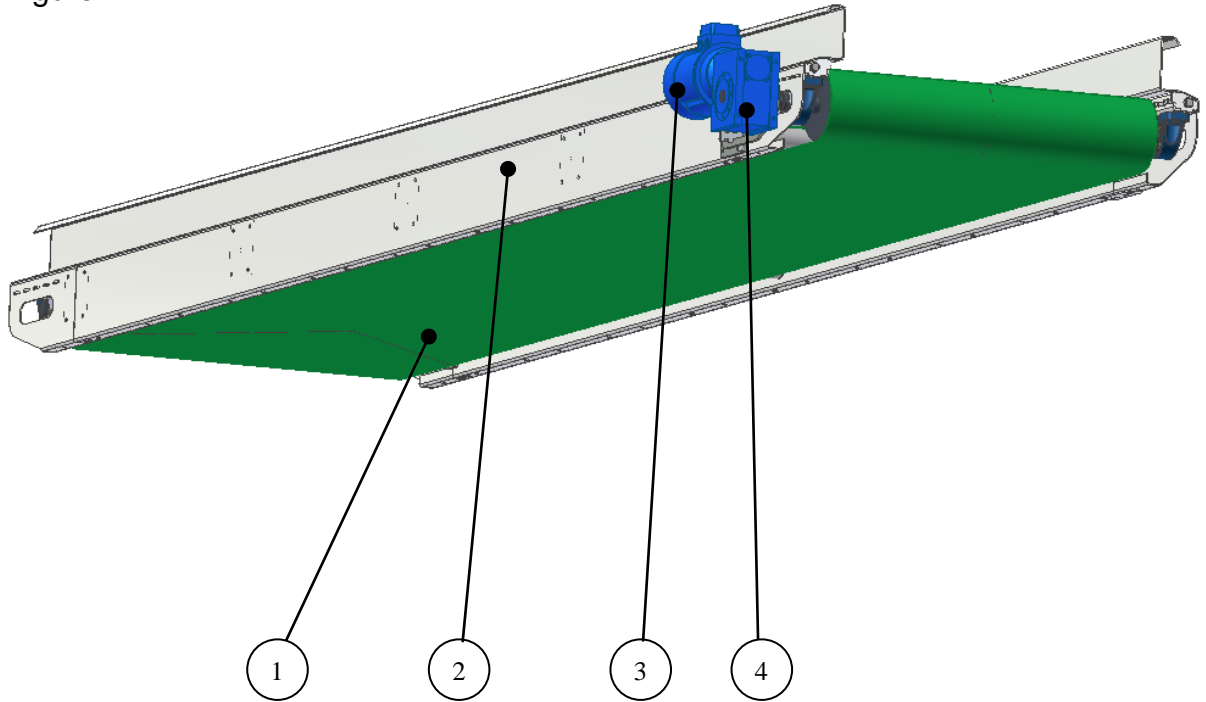

Figure 3

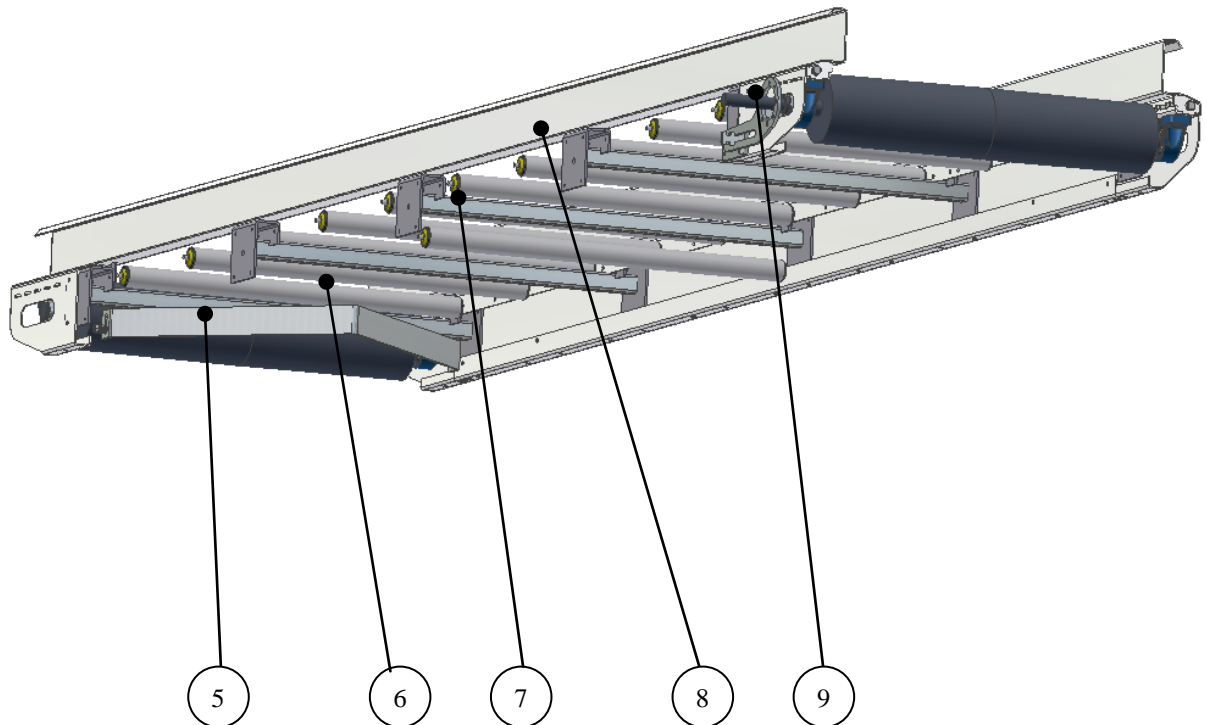
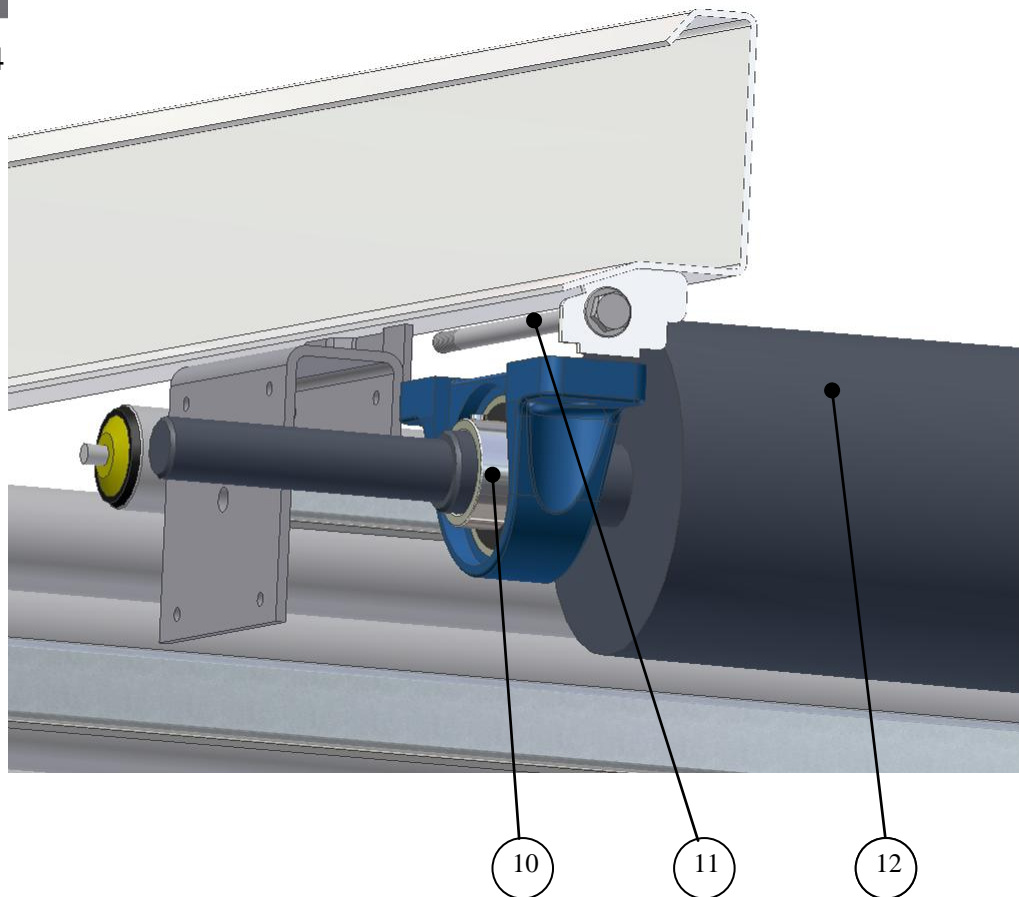

Figure 4



Page	Fig. nr.	Pos. nr	Betegnelse
5	2	1	Conveyerbelt
5	2	2	Sideplate
5	2	3	Motor
5	2	4	Gear
5	3	5	Roller
5	3	6	Beltscraper
5	3	7	Roller
5	3	8	Roller
5	3	9	Arm for motor and gear
6	4	10	Bearing
6	4	11	Adjustable screw
6	4	12	Driveroller



## 9.0 Declaration of conformity with EU

<b>Manufacturer</b>	
Firm:	A/S Skals Maskinfabrik
Address:	Hovedgaden 56 8832 Skals, Denmark
Telephone:	87 25 62 00

declares herewith, that

<b>Machine:</b>	<b>Conveyer/elevator</b>
Brand:	<b>TG/TM16</b>
Type, serial no., year:	

Is manufactured in accordance with the decisions of the Councils Directives:

- 1 Machinery Safety – Directive 98/37/EC
- 2 Low Voltage Equipment Directive (LVD) 2006/95/EEC
- 3 Electromagnetic Compatibility (EMC) Directive 89/336/EEC and 93/68/EEC as amended.

<b>Title:</b>	Productions Manager
Name:	Søren Lund Madsen
Firm:	A/S Skals Maskinfabrik

Date: \_\_\_\_\_

Signed:  \_\_\_\_\_

